

**Moffat Specification**

Flat belt type conveyor.  
Sensor limit switch at the end of the conveyor  
Emergency-stop button at each end.  
Speed adjustable from 0 to 12 metres/minute  
Maintenance-free drum motor

Dimensions

Length - 6000mm  
Depth - 550mm  
Height - 900mm  
Weight - 85kg

Power Supply

When supplied as a motorized belt only the power requirements is 13amp 1PH.  
Optional splash proof 13amp sockets for auxiliary equipment can be fitted, each optional 13 amp socket is protected by a 13amp R.C.B.O. fitted in a splash proof M.C.B. board.  
Power supply requirement is made bespoke for each site and depending on how many sockets are fitted.

Materials

1.2mm 304 Grade St/ Steel Chassis Top & Supports.  
0.7mm 430 Grade St Steel Ancillary Parts.

Installation

Castors :- Swivel Type With Brakes.

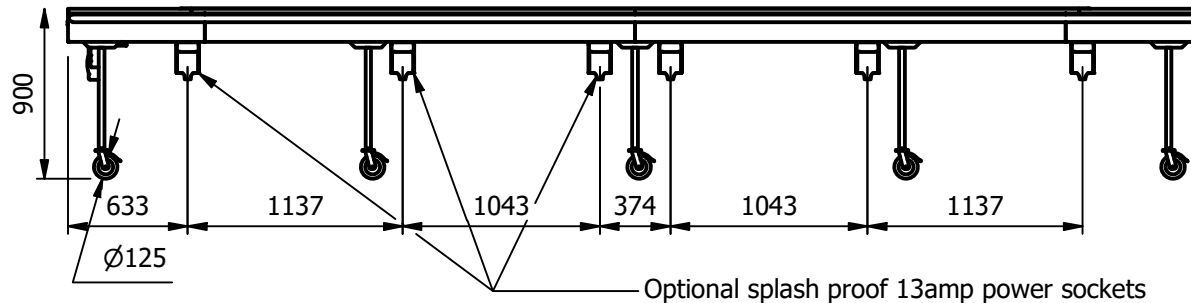
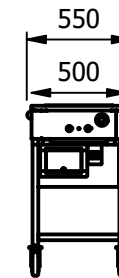

ALL SHEET METAL DIMENSIONS ARE I/S (INSIDE SIZES) (UNLESS OTHERWISE STATED)

ALL DIMENSIONS IN (mm), TOLERANCE = LINEAR ± 0.5mm, ANGULAR ± 0.5mm (OR AS STATED). ALL SHARP EDGES TO BE REMOVED FROM SHEET METAL PARTS

Product	CONVEYOR			Product No						
Description	CVB6M *** 6 METRE MOBILE BELT ***				<small>© No reproduction or publication of this drawing may be made, and no article may be manufactured or assembled in accordance with this drawing without prior written consent. This prohibition is a term of any contract relating to this drawing. Rights reserved under the Copyright Act 1956 as amended by the Design Copyright Act 1968.</small>					
Material/Finish	Thickness			Desp/Date						
Legacy P/N	Weight	85kg		Quote No.	Dwg No.	VCP-087993-1	Issue			
Client				SO Number	STANDARD		Drawn By	N.Raymen		
Client Project				Approved By			Date	16/02/2021		
E & R MOFFAT LTD, SEABEGS ROAD, BONNYBRIDGE, FK4 2BS, T: +44 (0)1324 812272, E: sales@ermoffat.co.uk, Web: www.ermoffat.co.uk						Scale	1 : 40	Sheet	1 / 2	A4

