

The soup station unit can be fitted in either the assisted service position as show with the drip tray on the operators side or alternatively set up as self service with the drip tray on the customers side.

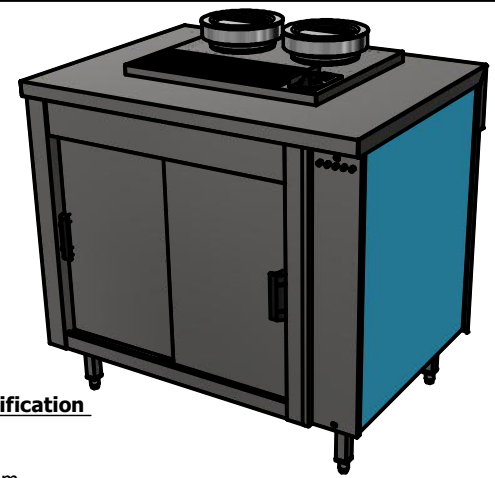

Moffat Specification

Dimensions

Width - 947mm
 Depth - 700mm
 Height - 900mm
 Weight - 70kg

Power Rating

0.70kw
 complete with a 2m long cord set & 13amp plug

Soup Station

Dry heat well with solid state elements
 Two Stainless steel Pots with lids
 2 x 4 litre capacity
 Complete with a removable drip tray with perforated lid

Capacity of ambient cupboard [usable inside space]

Width - 695mm
 Depth - 559mm
 Usable Height Bottom shelf - 210mm
 Usable Height Top Shelf - 195mm

400 off 6" Bowls stacked
 or
 4 off 1/1GN pans side by side 150mm deep 2 on top 2 on bottom

Materials

1.2mm 304 Grade St/ Steel Top & Supports
 0.7mm 430 Grade St/ Steel Internal Structure
 GN 1/1 Grid Shelves with 30mm x 30mm tube supports

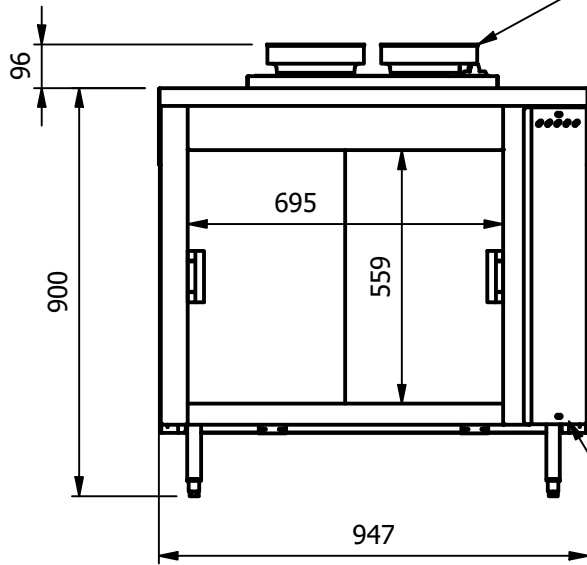

Removable pots and drip tray

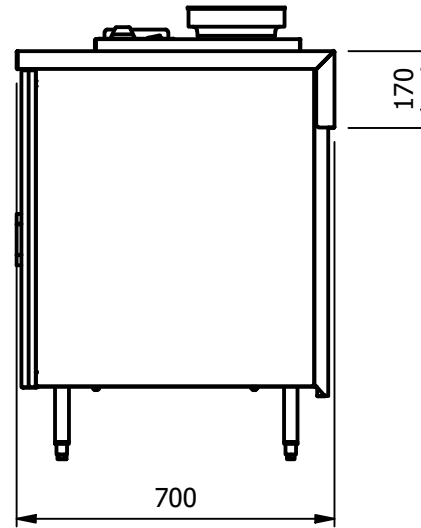

POWER CABLE ENTRY POINT

ALL SHEET METAL DIMENSIONS ARE I/S (INSIDE SIZES) (UNLESS OTHERWISE STATED)

ALL DIMENSIONS IN (mm), TOLERANCE = LINEAR ± 0.5mm, ANGULAR ± 0.5mm (OR AS STATED). ALL SHARP EDGES TO BE REMOVED FROM SHEET METAL PARTS

Product	COUNTERS			Product No				
Description	CSS2-7			<small>No reproduction or publication of this drawing may be made, and no article may be manufactured or assembled in accordance with this drawing without prior written consent. This prohibition is a term of any contract relating to this drawing. Rights reserved under the Copyright Act 1956 as amended by the Design Copyright Act 1968.</small>				
Material/Finish	Thickness			Desp/Date				
Legacy P/N	Weight	70kg		Quote No.	Dwg No.	CTRP-117961-1	Issue	
Client				SO Number	N/A		Drawn By	ABB
Client Project				Approved By	Date	11/05/2022		-
E & R MOFFAT LTD, SEABEGS ROAD, BONNYBRIDGE, FK4 2BS, T: +44 (0)1324 812272, E: sales@ermoffat.co.uk, Web: www.ermoffat.co.uk					Scale	.06	Sheet	1 / 4
								A4

