

Important Design Parameters

Allowances must be made for air venting.

The under slung compressor must have an unrestricted air flow.

Proper venting must be provided ensuring cool air from the room can be drawn in through the condensing coil and out the other side.

Warning

Do not install unit in draughty conditions where the air movement is greater than 0.2mtr/sec.

e.g.near entrance/exit doors, open windows, under air conditioning units or a ceiling mounted fan

Do not install units where there is high radiated heat, e.g. direct sunlight, room heaters, or bright spot lights.

Ambient room conditions must not exceed 25°C or a relative humidity of 60%.

Blocked vents will cause reduced refrigeration efficiency and lead to malfunction

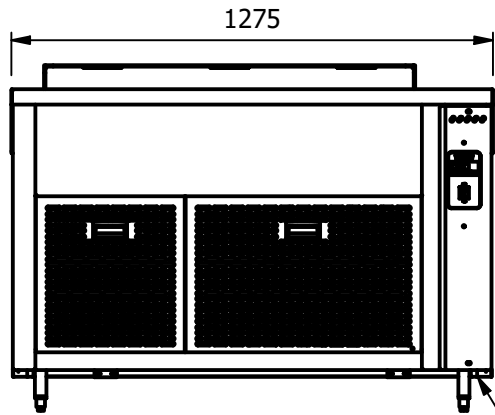
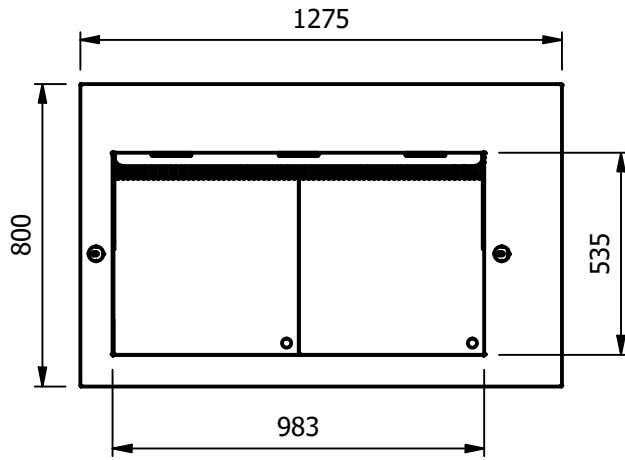

POWER CABLE ENTRY POINT

Warning
A clear space of 600mm must be left at the rear
<<AirFlow
AirFlow>>

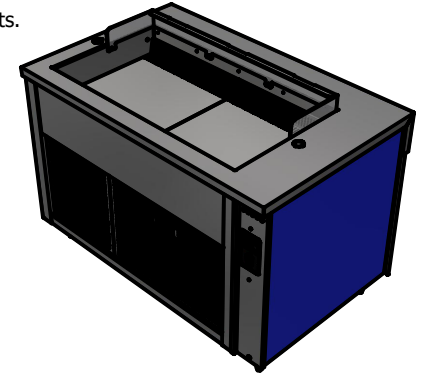
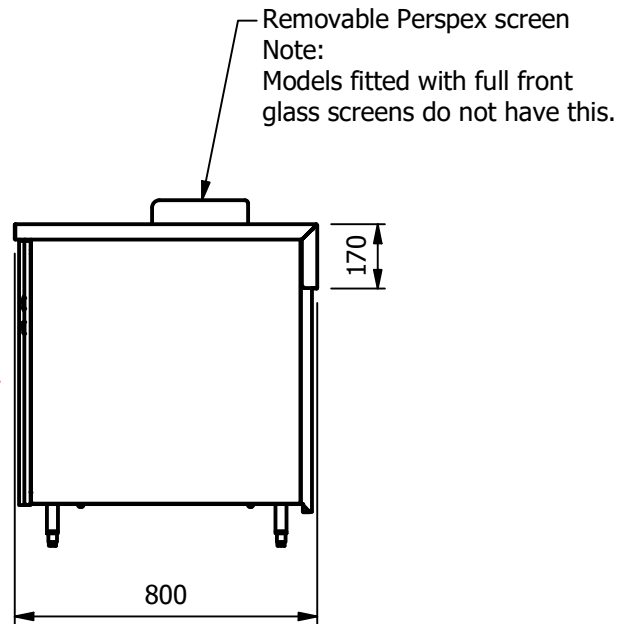

Moffat Specification

Chilled well with forced air refrigeration and self evaporation condensate system.

Dimensions

Width - 1275mm

Depth - 700mm

Height - 800mm

Weight - 155kg

Well - 983mm x 535mm x 130mm

Power Rating

1.2kw

complete with a 2m long cord set & 13amp plug

Materials

0.7mm 430 Grade St/Steel Gantry Hood

1.2mm 304 Grade St/ Steel Top & Supports

1.2mm 430 Grade St Steel Ancillary Parts

Gantry options

have LED Illumination and 6mm Tempered Glass

ALL SHEET METAL DIMENSIONS ARE I/S (INSIDE SIZES) (UNLESS OTHERWISE STATED)

ALL DIMENSIONS IN (mm), TOLERANCE = LINEAR ± 0.5mm, ANGULAR ± 0.5mm (OR AS STATED). ALL SHARP EDGES TO BE REMOVED FROM SHEET METAL PARTS

Product	COUNTERS			Product No						
Description	CRW3-8			<small>No reproduction or publication of this drawing may be made, and no article may be manufactured or assembled in accordance with this drawing without prior written consent. This prohibition is a term of any contract relating to this drawing. Rights reserved under the Copyright Act 1956 as amended by the Design Copyright Act 1968.</small>						
Material/Finish	Thickness		Desp/Date							
Legacy P/N	Weight	155kg	Quote No.							
Client				SO Number	N/A	Dwg No.	CTRP-117365-1	Issue		
Client Project				Approved By		Drawn By	ABB	-		
E & R MOFFAT LTD, SEABEGS ROAD, BONNYBRIDGE, FK4 2BS, T: +44 (0)1324 812272, E: sales@ermoffat.co.uk, Web: www.ermoffat.co.uk						Date	28/06/2021			
						Scale	1 : 20	Sheet	1 / 2	A4