

**Important Design Parameters**

Allowances must be made for air venting.  
 The under slung compressor must have an unrestricted air flow.  
 Proper venting must be provided ensuring cool air from the room can be drawn in through the condensing coil and out the other side.

**Warning**

Do not install unit in draughty conditions where the air movement is greater than 0.2mtr/sec.  
 e.g.near entrance/exit doors, open windows, under air conditioning units or a ceiling mounted fan  
 Do not install units where there is high radiated heat, e.g. direct sunlight, room heaters, or bright spot lights.  
 Ambient room conditions must not exceed 25°C or a relative humidity of 60%.  
 Blocked vents will cause reduced refrigeration efficiency and lead to malfunction

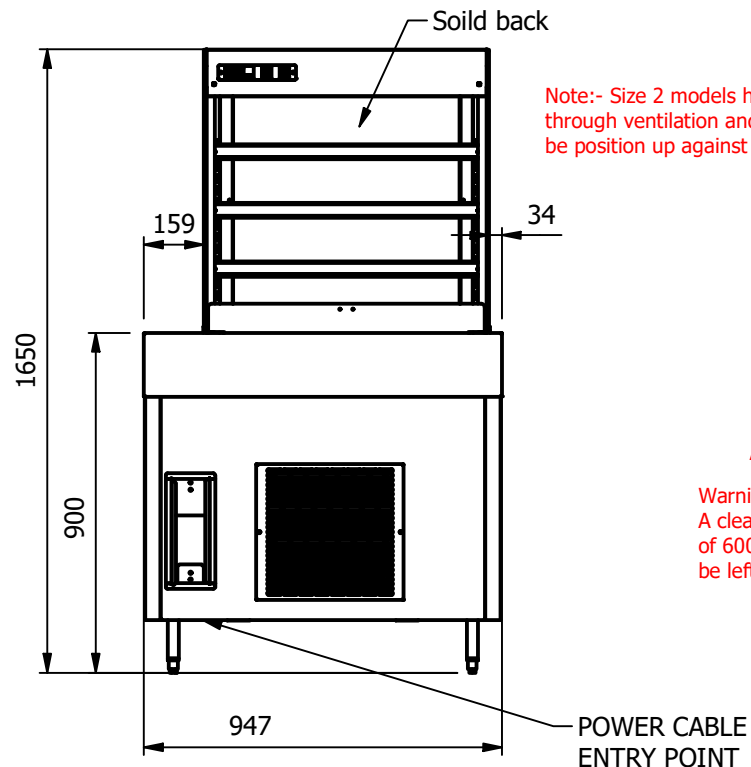
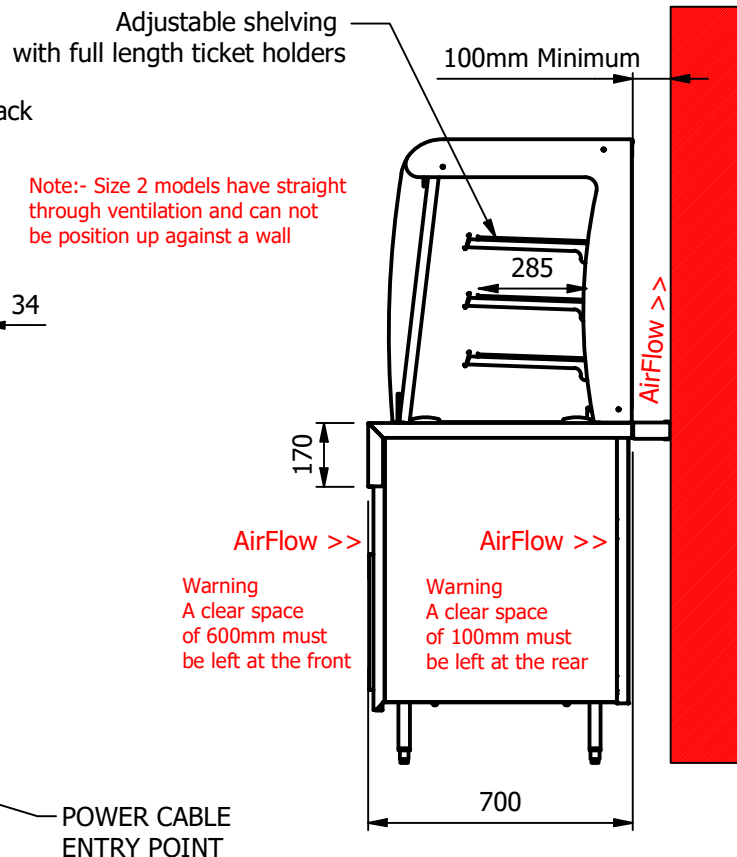
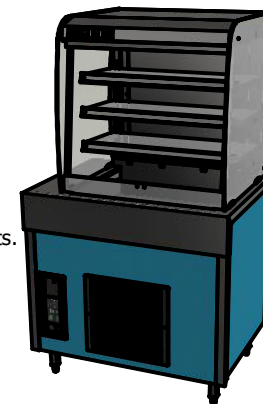

**Moffat Specification**

- Chilled display with forced air refrigeration and self evaporation condensate system.

**Dimensions**

Width - 947mm  
 Depth - 700mm (800mm with air flow spacer)  
 Height - 1650mm (900mm to work top)  
 Weight - 115kg

Well - 655mm x 495mm x 130mm

Shelves - 724mm x 285mm

**Power Rating**

1.5kw  
 complete with a 2m long cord set & 13amp plug

**Materials**

0.7mm 430 Grade St/Steel Gantry Hood  
 1.2mm 304 Grade St/ Steel Top & Supports  
 1.2mm 430 Grade St Steel Ancillary Parts

**Gantry options**

have LED Illumination and 6mm Tempered Glass

ALL SHEET METAL DIMENSIONS ARE I/S (INSIDE SIZES) (UNLESS OTHERWISE STATED)

ALL DIMENSIONS IN (mm), TOLERANCE = LINEAR ± 0.5mm, ANGULAR ± 0.5mm (OR AS STATED). ALL SHARP EDGES TO BE REMOVED FROM SHEET METAL PARTS

|   |           |       |             |  |          |               |           |
|---|-----------|-------|-------------|--|----------|---------------|-----------|
| Product   | COUNTERS  |       |             | Product No   |          |               |           |
| Description   | CRDFC2-7  |       |             | <small>No reproduction or publication of this drawing may be made, and no article may be manufactured or assembled in accordance with this drawing without prior written consent. This prohibition is a term of any contract relating to this drawing. Rights reserved under the Copyright Act 1956 as amended by the Design Copyright Act 1968.</small> |          |               |           |
| Material/Finish   | Thickness |       | Desp/Date   |  |          |               |           |
| Legacy P/N  | Weight    | 115kg | Quote No.   |  |          |               |           |
| Client  |           |       | SO Number   | N/A  | Dwg No.  | CTRP-116440-1 | Issue     |
| Client Project  |           |       | Approved By |  | Drawn By | ABB           | -         |
| E & R MOFFAT LTD, SEABEGS ROAD, BONNYBRIDGE, FK4 2BS, T: +44 (0)1324 812272, E: sales@ermoffat.co.uk, Web: www.ermoffat.co.uk |           |       |             |  | Date     | 28/06/2021    |           |
|   |           |       |             |  | Scale    | 1 : 20        | Sheet     |
|   |           |       |             |  |          |               | 1 / 2     |
|   |           |       |             |  |          |               | <b>A4</b> |