

Double switched power socket for cash till and single outlet back box for data EPOS systems.

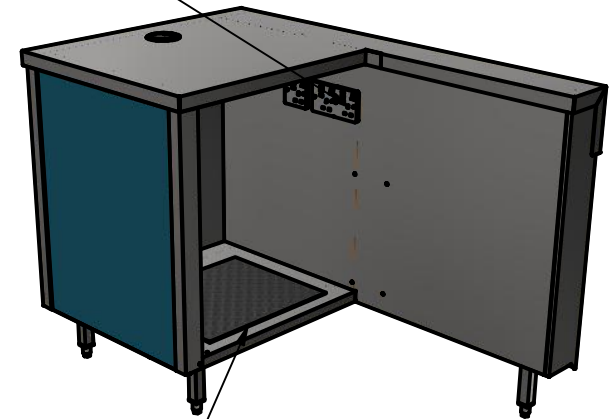

Foot rest with rubber mat

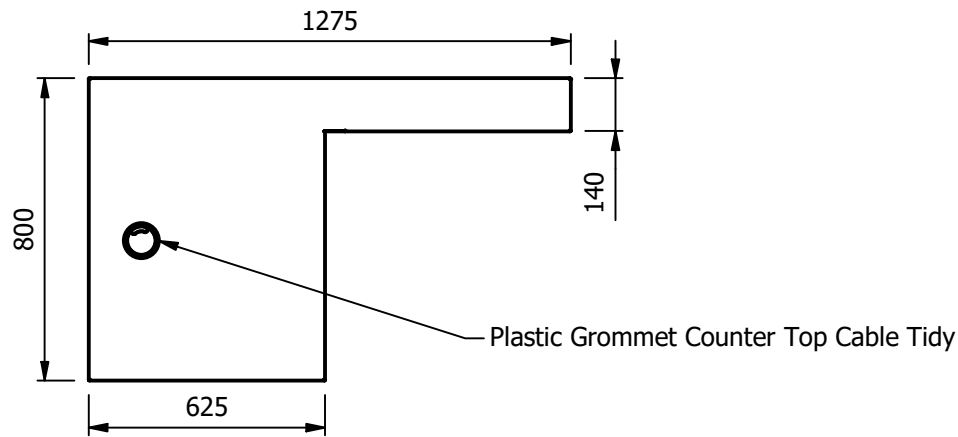
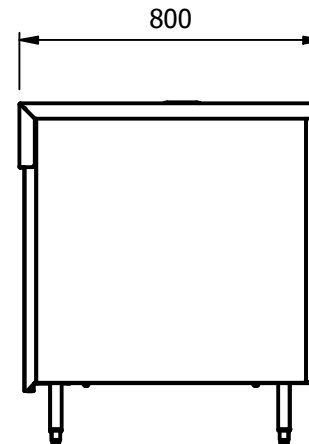
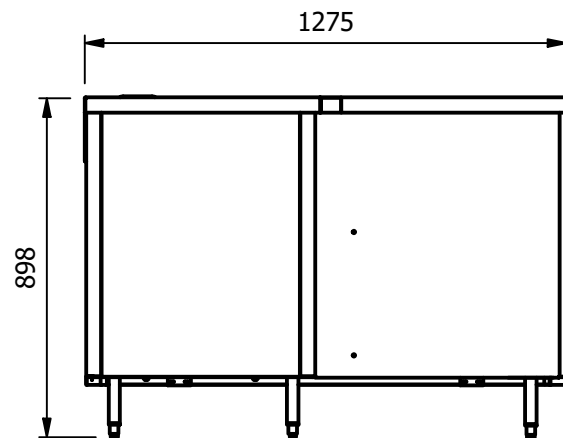

Moffat Specification

Cashier Section (Right hand configuration)
Solid stainless steel Worktop
provides a clean point of sales area.

Dimensions

Width - 1275mm
Depth - 800mm
Height - 900mm
Weight - 65kg

Power Rating

2.9 [13amp Double socket]
complete with a 2m long cord set & 13amp plug

Materials

1.2mm 304 Grade St/ Steel Top & Supports
0.7mm 430 Grade St/ Steel Internal Structure

ALL SHEET METAL DIMENSIONS ARE I/S (INSIDE SIZES) (UNLESS OTHERWISE STATED)

ALL DIMENSIONS IN (mm), TOLERANCE = LINEAR ± 0.5mm, ANGULAR ± 0.5mm (OR AS STATED). ALL SHARP EDGES TO BE REMOVED FROM SHEET METAL PARTS

Product	COUNTERS			Product No							
Description	CRCS-8			<small>© No reproduction or publication of this drawing may be made, and no article may be manufactured or assembled in accordance with this drawing without prior written consent. This prohibition is a term of any contract relating to this drawing. Rights reserved under the Copyright Act 1956 as amended by the Design Copyright Act 1968.</small>							
Material/Finish	Thickness			Desp/Date							
Legacy P/N	Weight	65kg		Quote No.	Dwg No.	CTRP-114216-1	Issue				
Client				SO Number	N/A		Drawn By	N.Raymen			
Client Project				Approved By			Date	13/04/2022			
E & R MOFFAT LTD, SEABEGS ROAD, BONNYBRIDGE, FK4 2BS, T: +44 (0)1324 812272, E: sales@ermoffat.co.uk, Web: www.ermoffat.co.uk							Scale	1 : 20	Sheet	1 / 2	A4

