

Double switched power socket for cash till and single outlet back box for data EPOS systems.

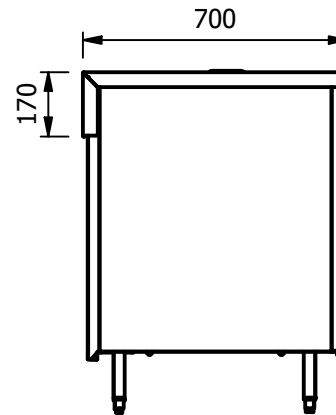
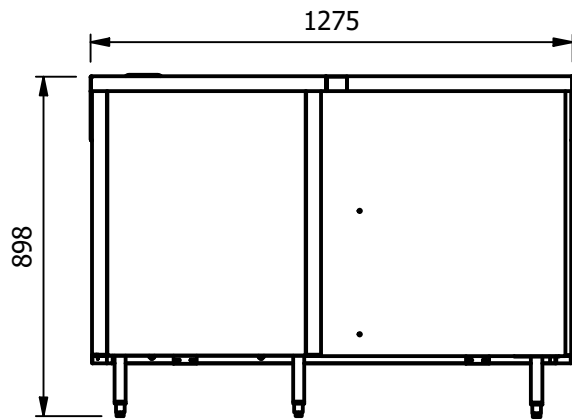
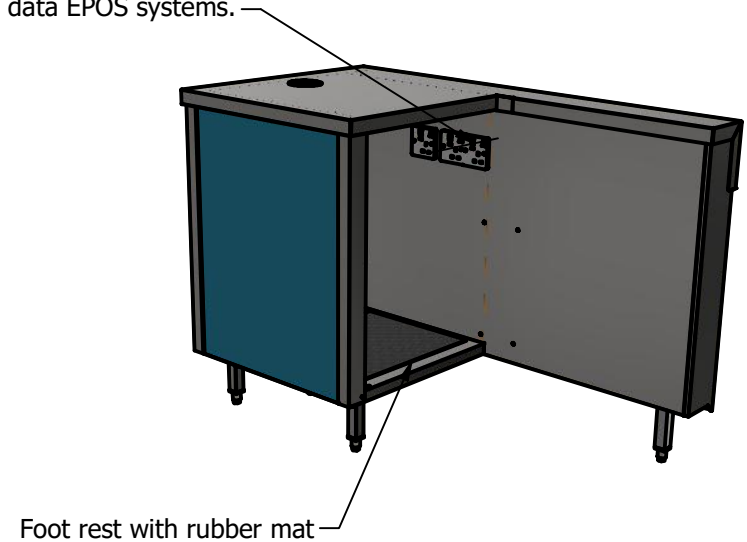
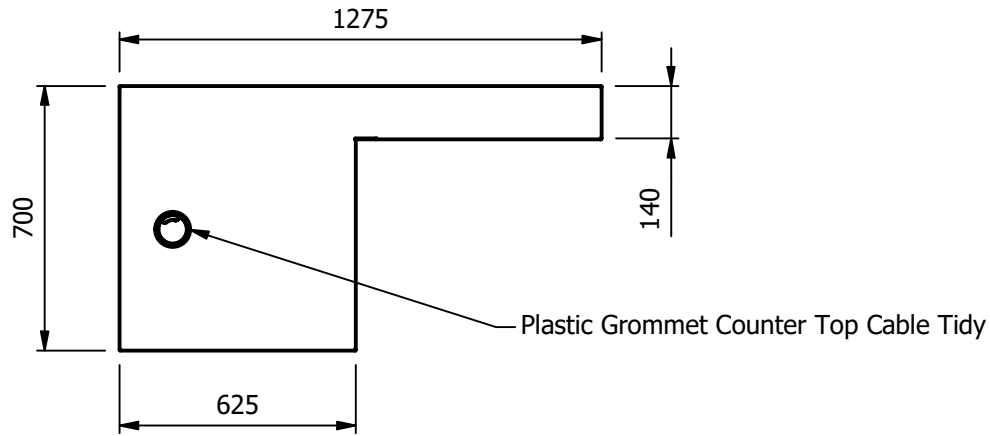

Moffat Specification

Cashier Section (Right hand configuration)
Solid stainless steel Worktop provides a clean point of sales area.

Dimensions

Width - 1275mm
Depth - 700mm
Height - 900mm
Weight - 55kg

Power Rating

2.9 [13amp Double socket]
complete with a 2m long cord set & 13amp plug

Materials

1.2mm 304 Grade St/ Steel Top & Supports
0.7mm 430 Grade St/ Steel Internal Structure

ALL SHEET METAL DIMENSIONS ARE I/S (INSIDE SIZES) (UNLESS OTHERWISE STATED)

ALL DIMENSIONS IN (mm), TOLERANCE = LINEAR ± 0.5mm, ANGULAR ± 0.5mm (OR AS STATED). ALL SHARP EDGES TO BE REMOVED FROM SHEET METAL PARTS

Product	COUNTERS			Product No				
Description	CRCS-7							
Material/Finish	Thickness		Desp/Date					
Legacy P/N	Weight	55kg	Quote No.					
Client			SO Number	N/A	Dwg No.	CTRP-113274-1	Issue	
Client Project			Approved By		Drawn By	N.Raymen		
E & R MOFFAT LTD, SEABEGS ROAD, BONNYBRIDGE, FK4 2BS, T: +44 (0)1324 812272, E: sales@ermoffat.co.uk, Web: www.ermoffat.co.uk					Date	13/04/2022		
					Scale	1 : 20	Sheet	1 / 2 A4

No reproduction or publication of this drawing may be made, and no article may be manufactured or assembled in accordance with this drawing without prior written consent. This prohibition is a term of any contract relating to this drawing. Rights reserved under the Copyright Act 1956 as amended by the Design Copyright Act 1968.