

1 CR8P Oven with High stand (CRPHS)

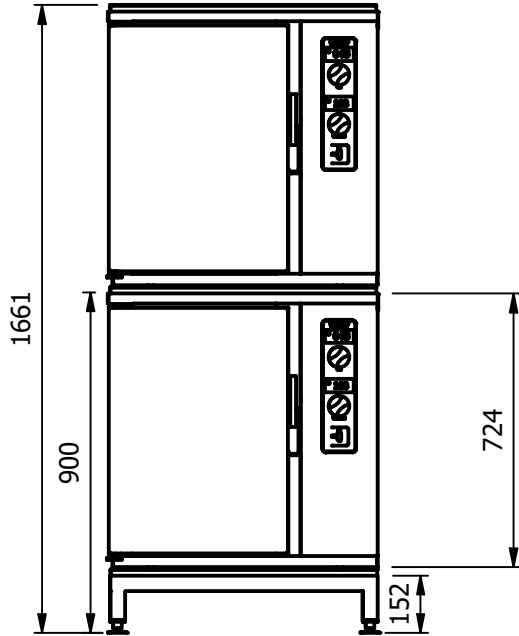

2 CR8 ovens with Low stand (CRPLS)

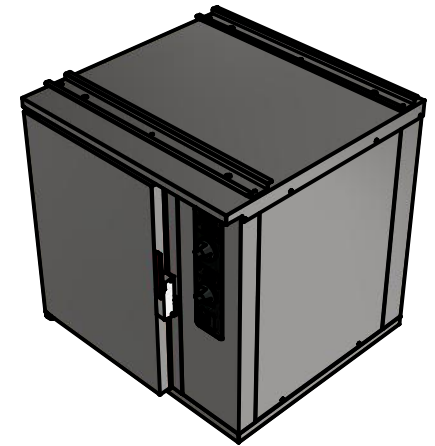
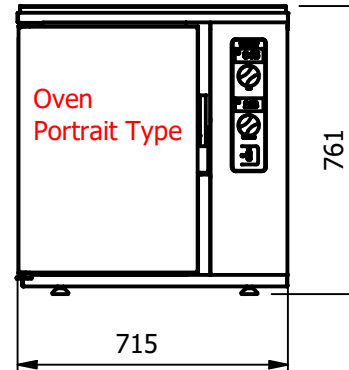
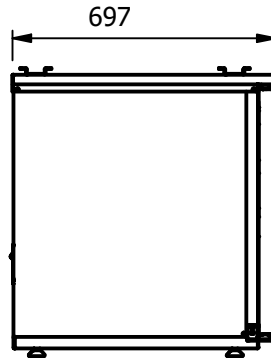
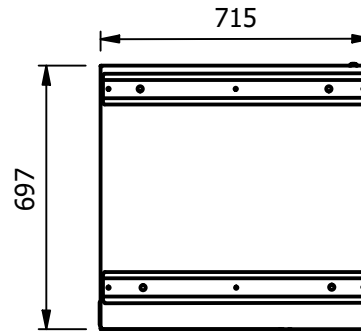

Moffat Specification

Dimensions

Width - 715mm

Depth - 695mm

Height - 761mm

Weight - 120kg

Power Rating options

2.9kw [13amp 1PH] complete with a 2m long cord set & 13amp plug.

5.7 kw. [16amp 3PH] or [32amp 1PH] complete with a 2m long cord set & plug.

Materials

1.2mm 304 & 430 Grade St/ Steel Top & Supports.
0.7 & 1.2mm 430 Grade St Steel Ancillary Parts.

Fully Insulated Compartment.

Oven

Capacity 98lites

8off Gn1/1 Grid shelf positions @ 71mm pitch

ALL SHEET METAL DIMENSIONS ARE I/S (INSIDE SIZES) (UNLESS OTHERWISE STATED)

ALL DIMENSIONS IN (mm), TOLERANCE = LINEAR ± 0.5mm, ANGULAR ± 0.5mm (OR AS STATED). ALL SHARP EDGES TO BE REMOVED FROM SHEET METAL PARTS

Product	REGEN OVENS			Product No			
Description	CR8P						
Material/Finish	Thickness			Desp/Date			
Legacy P/N	Weight	120kg		Quote No.			
Client				SO Number	N/A		-
Client Project				Approved By			
				Dwg No.	VGEN-093481		Issue
				Drawn By	ABB		
				Date	12/10/2018		
E & R MOFFAT LTD, SEABEGS ROAD, BONNYBRIDGE, FK4 2BS, T: +44 (0)1324 812272, E: sales@ermoffat.co.uk, Web: www.ermoffat.co.uk				Scale	1 : 20		Sheet 1 / 2
							A4

No reproduction or publication of this drawing may be made, and no article may be manufactured or assembled in accordance with this drawing without prior written consent. This prohibition is a term of any contract relating to this drawing. Rights reserved under the Copyright Act 1956 as amended by the Design Copyright Act 1968.

