

Double switched power socket for cash till and single outlet back box for data EPOS systems.

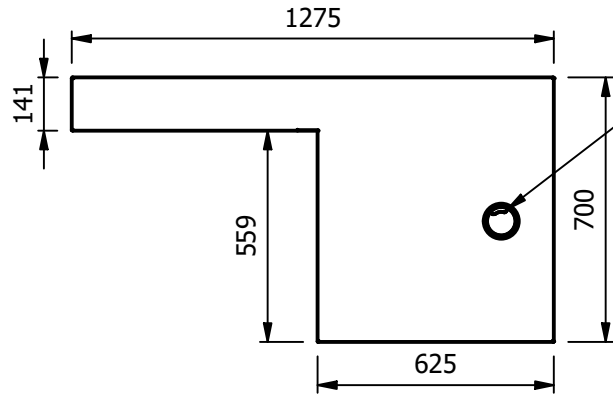

Plastic Grommet Counter Top Cable Tidy

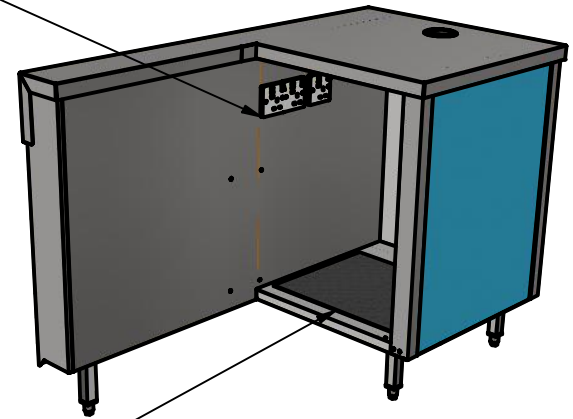

Foot rest with rubber mat

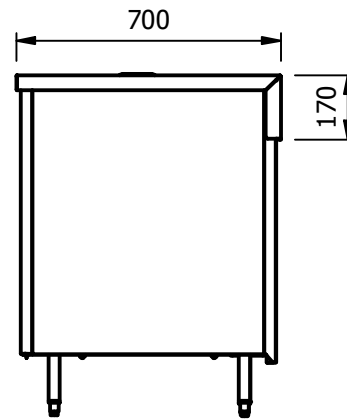
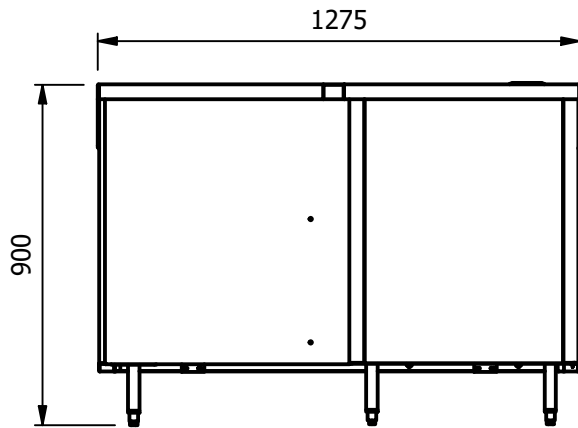

Moffat Specification

Cashier Section (Left hand configuration)
Solid stainless steel Worktop provides a clean point of sales area.

Dimensions

Width - 1275mm
Depth - 700mm
Height - 900mm
Weight - 55kg

Power Rating

2.9 [13amp Double socket]
complete with a 2m long cord set & 13amp plug

Materials

1.2mm 304 Grade St/ Steel Top & Supports
0.7mm 430 Grade St/ Steel Internal Structure

ALL SHEET METAL DIMENSIONS ARE I/S (INSIDE SIZES) (UNLESS OTHERWISE STATED)

ALL DIMENSIONS IN (mm), TOLERANCE = LINEAR ± 0.5mm, ANGULAR ± 0.5mm (OR AS STATED). ALL SHARP EDGES TO BE REMOVED FROM SHEET METAL PARTS

Product	COUNTERS			Product No	 <p><small>No reproduction or publication of this drawing may be made, and no article may be manufactured or assembled in accordance with this drawing without prior written consent. This prohibition is a term of any contract relating to this drawing. Rights reserved under the Copyright Act 1956 as amended by the Design Copyright Act 1968.</small></p>			
Description	CLCS-7							
Material/Finish	Thickness		Desp/Date					
Legacy P/N	Weight	55kg	Quote No.					
Client			SO Number	N/A	Dwg No.	CTRP-112155-1	Issue	
Client Project			Approved By		Drawn By	N.Raymen		
E & R MOFFAT LTD, SEABEGS ROAD, BONNYBRIDGE, FK4 2BS, T: +44 (0)1324 812272, E: sales@ermoffat.co.uk, Web: www.ermoffat.co.uk					Date	13/04/2022		
					Scale	1 : 20	Sheet	1 / 2 A4