

**Moffat Specification**

Neo-Ceram glass hot Top  
The Stainless steel top inset with Neo Ceram glass panels provides a clean hot serving area.

Dry Heat  
Fan Assisted Hotcupboard

Power Rating  
1.26kw  
Complete with a 2m long cord set  
Removable Fan heating System Sahara Fan Model SF309

Materials  
1.2mm 304 Grade St/ Steel Top & Supports  
0.7mm 430 Grade St/ Steel Internal Structure  
GN 1/1 Grid Shelves with 30mm x 30mm tube supports

Dimensions  
Width - 947mm  
Depth - 800mm  
Height - 900mm  
Weight - 73kg

Hot Surface Area  
653mm x 531mm

Capacity of Hot Cupboard [usable inside space]  
Width - 695mm  
Depth - 559mm  
Usable Height Bottom shelf - 210mm  
Usable Height Top Shelf - 195mm

25 covers & meals [10" plated meals stacked using plate covers]  
or  
95 off 10" plates stacked for heating  
or  
4 off 1/1GN pans side by side 150mm deep 2 on top 2 on bottom

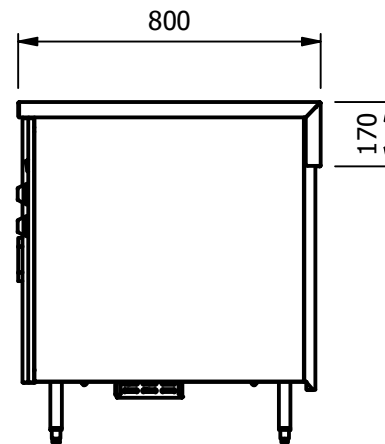
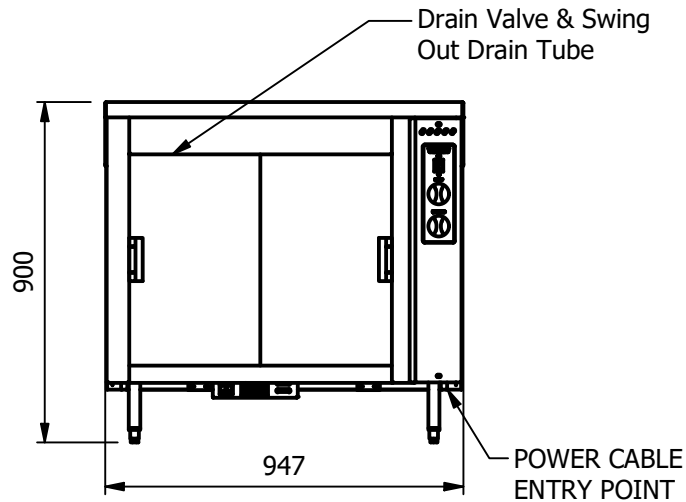

ALL SHEET METAL DIMENSIONS ARE I/S (INSIDE SIZES) (UNLESS OTHERWISE STATED)

ALL DIMENSIONS IN (mm), TOLERANCE = LINEAR ± 0.5mm, ANGULAR ± 0.5mm (OR AS STATED). ALL SHARP EDGES TO BE REMOVED FROM SHEET METAL PARTS

Product	COUNTERS			Product No							
Description	CHT2-8			<small>No reproduction or publication of this drawing may be made, and no article may be manufactured or assembled in accordance with this drawing without prior written consent. This prohibition is a term of any contract relating to this drawing. Rights reserved under the Copyright Act 1956 as amended by the Design Copyright Act 1968.</small>							
Material/Finish	Thickness			Desp/Date							
Legacy P/N	Weight	73kg		Quote No.	Dwg No.	CTRP-114096-1	Issue				
Client				SO Number	N/A		Drawn By	N.Raymen			
Client Project				Approved By			Date	28/06/2021			
E & R MOFFAT LTD, SEABEGS ROAD, BONNYBRIDGE, FK4 2BS, T: +44 (0)1324 812272, E: sales@ermoffat.co.uk, Web: www.ermoffat.co.uk							Scale	1 : 20	Sheet	1 / 2	A4

