

Moffat Specification

Bainmarie well "wet or dry"
 Can Be used dry heat or wet heat using hot water and steam.
 The open bath is designed to hold Gastronorm pans and heats via solid state elements fitted externally on the base of the bath, additional excess residual hot air from the hot cupboard is also used to maintain temperature which gives energy saving efficiency.

- Dry Heat
 Fan Assisted Hotcupboard

- Power Rating
 3.5kw
 Complete with a 2m long cord set and 16amp 1PH commando type plug
 Removable Fan heating System Sahara Fan Model SF315

- Materials
 1.2mm 304 Grade St/ Steel Top & Supports
 0.7mm 430 Grade St/ Steel Internal Structure
 GN 1/1 Grid Shelves with 30mm x 30mm tube supports

- Dimensions
 Width - 1931mm
 Depth - 800mm
 Height - 900mm
 Weight - 118kg

- Capacity of Bainmarie
 Five GN1/1 pans up to 150mm deep
 [Note:-pans are not supplied, available at extra cost]

- Capacity of Hot Cupboard [usable inside space]
 Width - 1679mm
 Depth - 559mm
 Usable Height Bottom shelf - 210mm
 Usable Height Top Shelf - 195mm

60 covers & meals [10" plated meals stacked using plate covers]
 or
 228 off 10" plates stacked for heating
 or
 10 off 1/1GN pans side by side 150mm deep 5 on top 5 on bottom

Drain Valve & Swing
 Out Drain Tube

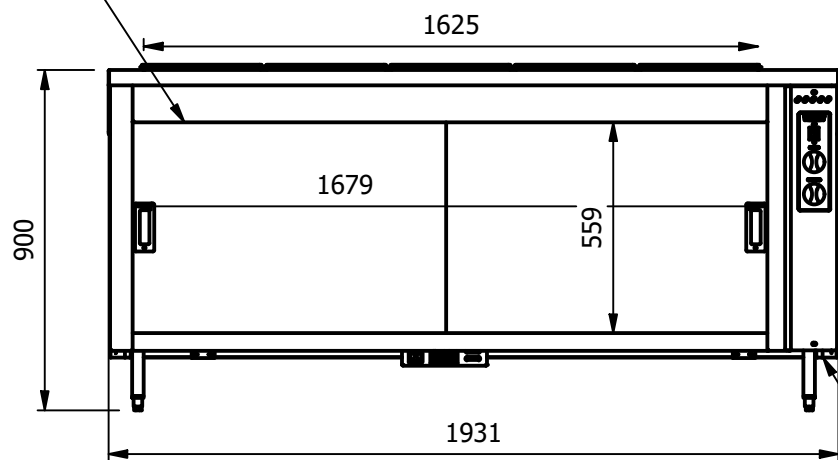

POWER CABLE
 ENTRY POINT

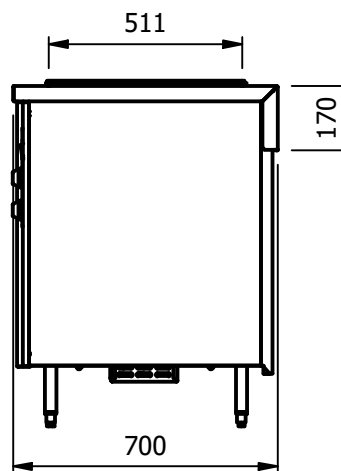

ALL SHEET METAL DIMENSIONS ARE I/S (INSIDE SIZES) (UNLESS OTHERWISE STATED)

ALL DIMENSIONS IN (mm), TOLERANCE = LINEAR ± 0.5mm, ANGULAR ± 0.5mm (OR AS STATED). ALL SHARP EDGES TO BE REMOVED FROM SHEET METAL PARTS

| | | | | | | | |
|---|-----------|-------|--|-------------|---------------|--|---|
| Product | COUNTERS | | | Product No | | | |
| Description | CHB5-7 | | | | | | |
| Material/Finish | Thickness | | | Desp/Date | | | |
| Legacy P/N | Weight | 118kg | | Quote No. | | | |
| Client | | | | SO Number | N/A | |  |
| Client Project | | | | Approved By | | | |
| | | | | Dwg No. | CTRP-113854-1 | | Issue |
| | | | | Drawn By | ABB | | - |
| | | | | Date | 28/06/2021 | | |
| E & R MOFFAT LTD, SEABEGS ROAD, BONNYBRIDGE, FK4 2BS, T: +44 (0)1324 812272, E: sales@ermoffat.co.uk, Web: www.ermoffat.co.uk | | | | Scale | 1 : 20 | | Sheet 1 / 2 A4 |

No reproduction or publication of this drawing may be made, and no article may be manufactured or assembled in accordance with this drawing without prior written consent. This prohibition is a term of any contract relating to this drawing. Rights reserved under the Copyright Act 1956 as amended by the Design Copyright Act 1968.