

Moffat Specification

Bainmarie well "wet or dry"

Can Be used dry heat or wet heat using hot water and steam. The open bath is designed to hold Gastronorm pans and heats via solid state elements fitted externally on the base of the bath, additional excess residual hot air from the hot cupboard is also used to maintain temperature which gives energy saving efficiency.

Dry Heat

Fan Assisted Hotcupboard

Power Rating

3.68kw

Complete with a 2m long cord set

Removable Fan heating System Sahara Fan Model SF315

Materials

1.2mm 304 Grade St/ Steel Top & Supports

0.7mm 430 Grade St/ Steel Internal Structure

GN 1/1 Grid Shelves with 30mm x 30mm tube supports

Dimensions

Width - 1603mm

Depth - 700mm

Height - 900mm

Weight - 100kg

Capacity of Hot Cupboard [usable inside space]

Width - 1351mm

Depth - 559mm

Usable Height Bottom shelf - 210mm

Usable Height Top Shelf - 195mm

50 covers & meals [10" plated meals stacked using plate covers]

or

190 off 10" plates stacked for heating

or

8 off 1/1GN pans side by side 150mm deep 4 on top 4 on bottom

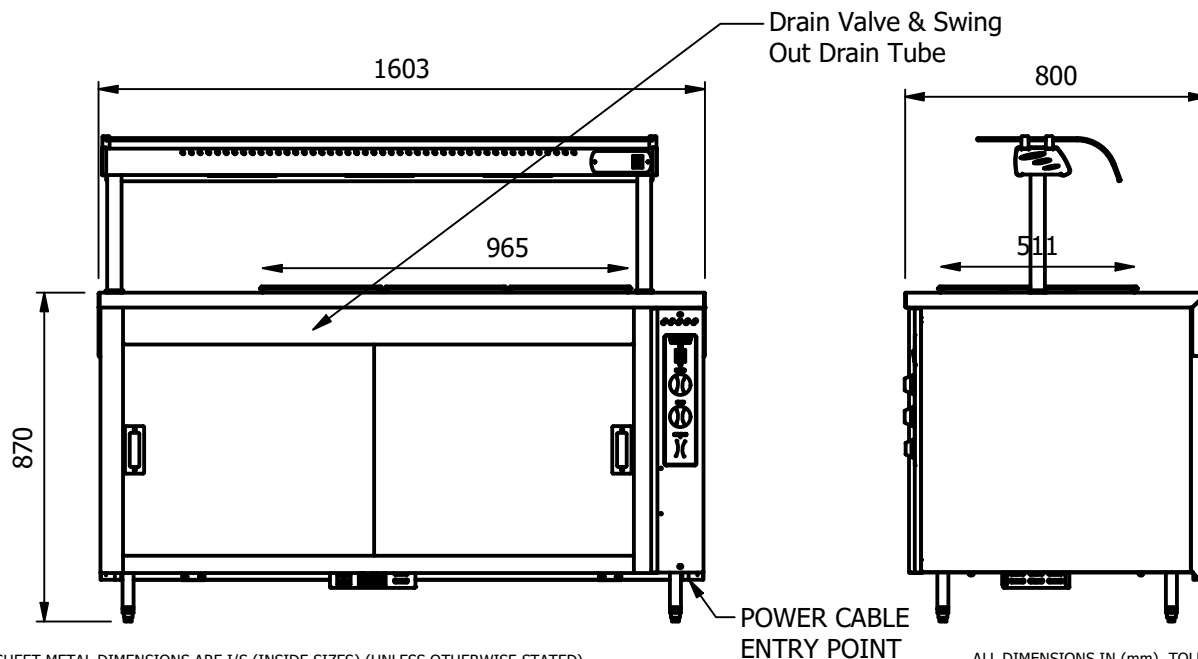

ALL SHEET METAL DIMENSIONS ARE I/S (INSIDE SIZES) (UNLESS OTHERWISE STATED)

ALL DIMENSIONS IN (mm), TOLERANCE = LINEAR ± 0.5mm, ANGULAR ± 0.5mm (OR AS STATED). ALL SHARP EDGES TO BE REMOVED FROM SHEET METAL PARTS

Product	COUNTERS			Product No					
Description	CHB3HT1-8								
Material/Finish	Thickness			Desp/Date					
Legacy P/N	Weight	100kg		Quote No.					
Client				SO Number	N/A		Dwg No.	CTRP-139924-1	
Client Project				Approved By			Drawn By	ABB	
							Date	28/06/2021	
E & R MOFFAT LTD, SEABEGS ROAD, BONNYBRIDGE, FK4 2BS, T: +44 (0)1324 812272, E: sales@ermoffat.co.uk, Web: www.ermoffat.co.uk							Scale	1 : 20	
							Sheet	1 / 2	
								A4	

No reproduction or publication of this drawing may be made, and no article may be manufactured or assembled in accordance with this drawing without prior written consent. This prohibition is a term of any contract relating to this drawing. Rights reserved under the Copyright Act 1956 as amended by the Design Copyright Act 1968.

