

**Moffat Specification**

Bainmarie well "wet or dry"

Can Be used dry heat or wet heat using hot water and steam. The open bath is designed to hold Gastronorm pans and heats via solid state elements fitted externally on the base of the bath, additional excess residual hot air from the hot cupboard is also used to maintain temperature which gives energy saving efficiency.

- Dry Heat  
Fan Assisted Hotcupboard

- Power Rating  
2.61kw  
Complete with a 2m long cord set  
Removable Fan heating System Sahara Fan Model SF315

- Materials  
1.2mm 304 Grade St/ Steel Top & Supports  
0.7mm 430 Grade St/ Steel Internal Structure  
GN 1/1 Grid Shelves with 30mm x 30mm tube supports

- Dimensions  
Width - 1275mm  
Depth - 700mm  
Height - 900mm  
Weight - 81kg

- Capacity of Bainmarie  
Three GN1/1 pans up to 150mm deep  
[Note:-pans are not supplied, available at extra cost]

- Capacity of Hot Cupboard [usable inside space]  
Width - 1023mm  
Depth - 559mm  
Usable Height Bottom shelf - 210mm  
Usable Height Top Shelf - 195mm

35 covers & meals [10" plated meals stacked using plate covers]  
or  
133 off 10" plates stacked for heating  
or  
6 off 1/1GN pans side by side 150mm deep 3 on top 3 on bottom

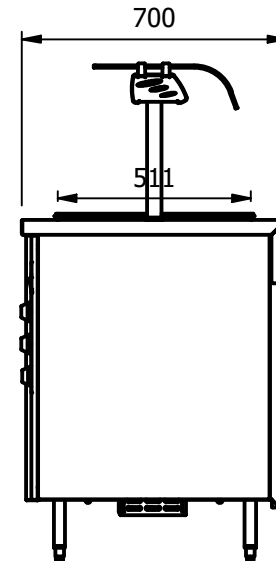
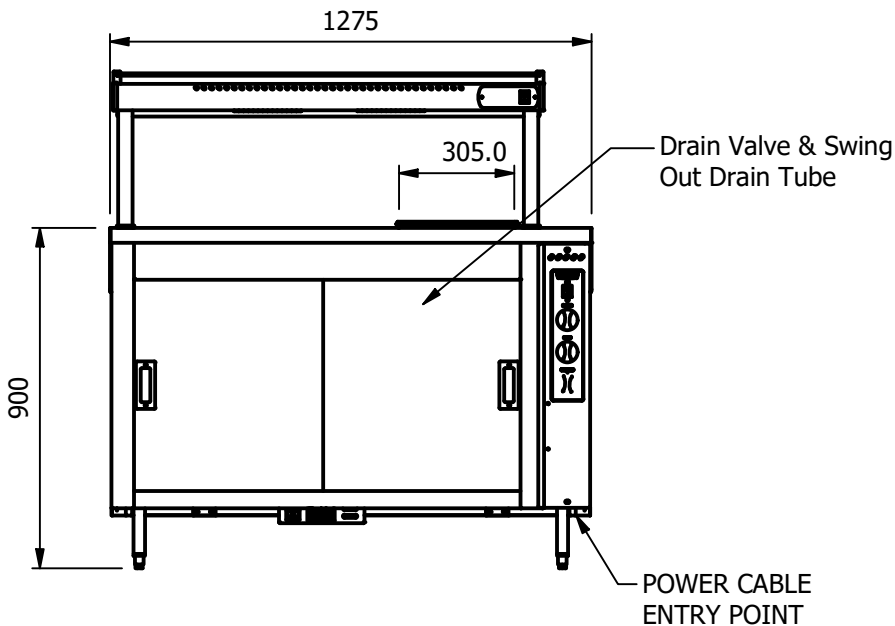

ALL SHEET METAL DIMENSIONS ARE I/S (INSIDE SIZES) (UNLESS OTHERWISE STATED)

ALL DIMENSIONS IN (mm), TOLERANCE = LINEAR ± 0.5mm, ANGULAR ± 0.5mm (OR AS STATED). ALL SHARP EDGES TO BE REMOVED FROM SHEET METAL PARTS

Product	COUNTERS			Product No					
Description	CHB1HT2-7								
Material/Finish	Thickness		Desp/Date		<small>No reproduction or publication of this drawing may be made, and no article may be manufactured or assembled in accordance with this drawing without prior written consent. This prohibition is a term of any contract relating to this drawing. Rights reserved under the Copyright Act 1956 as amended by the Design Copyright Act 1968.</small>	Dwg No.	CTRP-139895-1	Issue	
Legacy P/N	Weight	81kg	Quote No.						
Client			SO Number	N/A	Drawn By	ABB		-	
Client Project			Approved By		Date	28/06/2021			
E & R MOFFAT LTD, SEABEGS ROAD, BONNYBRIDGE, FK4 2BS, T: +44 (0)1324 812272, E: sales@ermoffat.co.uk, Web: www.ermoffat.co.uk					Scale	1 : 20	Sheet	1 / 2	<b>A4</b>