

Important Design Parameters

Allowances must be made for air venting.  
 The under slung compressor must have an unrestricted air flow.  
 Proper venting must be provided ensuring cool air from the room can be drawn in through the condensing coil and out the other side.

Warning

Do not install unit in draughty conditions where the air movement is greater than 0.2mtr/sec.  
 e.g. near entrance/exit doors, open windows, under air conditioning units or a ceiling mounted fan  
 Do not install units where there is high radiated heat, e.g. direct sunlight, room heaters, or bright spot lights.  
 Ambient room conditions must not exceed 25°C or a relative humidity of 60%.  
 Blocked vents will cause reduced refrigeration efficiency and lead to malfunction

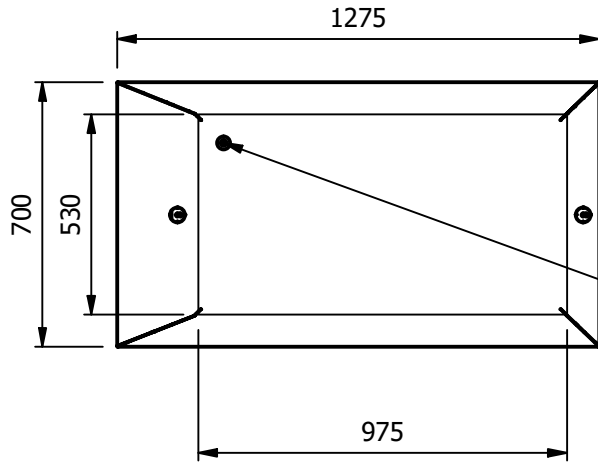

Recessed Top with a drain and shut off valve.  
 The drain can be connected into a main waste system or alternatively simply place a suitable vessel under to catch the excess water after service

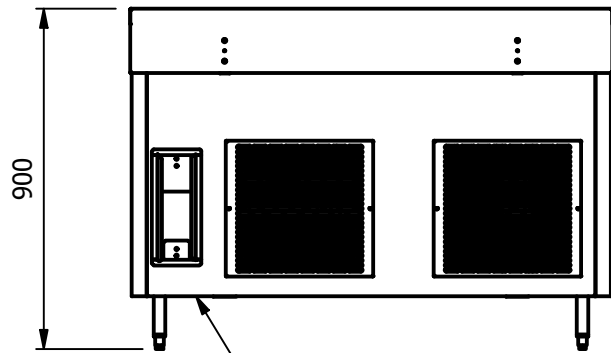
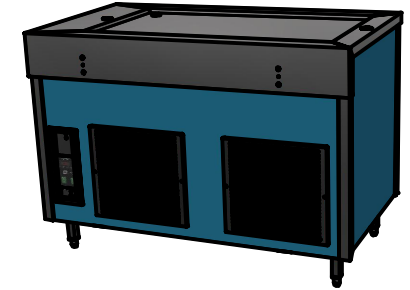

POWER CABLE  
ENTRY POINT

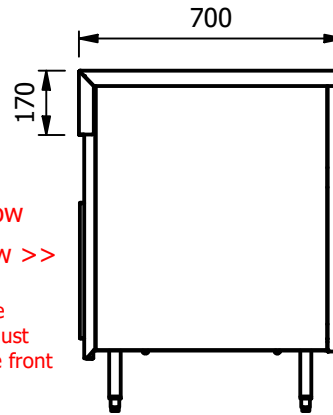

<<AirFlow  
AirFlow >>  
Warning  
A clear space  
of 600mm must  
be left at the front

Moffat Specification

Chilled Frost Tops with contact refrigeration and self evaporation condensate system.

Dimensions

Width - 1275mm  
 Depth - 700mm  
 Height - 900mm  
 Weight - 130kg  
 Recess Top - 975mm x 530mm x 15mm

Power Rating

1.0kw  
 complete with a 2m long cord set & 13amp plug

Materials

0.7mm 430 Grade St/Steel Gantry Hood  
 1.2mm 304 Grade St/ Steel Top & Supports  
 1.2mm 430 Grade St Steel Ancillary Parts

Gantry options

have LED Illumination and 6mm Tempered Glass

ALL SHEET METAL DIMENSIONS ARE I/S (INSIDE SIZES) (UNLESS OTHERWISE STATED)

ALL DIMENSIONS IN (mm), TOLERANCE = LINEAR ± 0.5mm, ANGULAR ± 0.5mm (OR AS STATED). ALL SHARP EDGES TO BE REMOVED FROM SHEET METAL PARTS

Product	COUNTERS			Product No							
Description	CFT3FC-7										
Material/Finish	Thickness			Desp/Date							
Legacy P/N	Weight	130kg		Quote No.	Dwg No.		CTRP-118701-1		Issue		
Client				SO Number	N/A		Drawn By	ABB			
Client Project				Approved By			Date	28/06/2021			
E & R MOFFAT LTD, SEABEGS ROAD, BONNYBRIDGE, FK4 2BS, T: +44 (0)1324 812272, E: sales@ermoffat.co.uk, Web: www.ermoffat.co.uk							Scale	1 : 20	Sheet	1 / 2	<b>A4</b>

No reproduction or publication of this drawing may be made, and no article may be manufactured or assembled in accordance with this drawing without prior written consent. This prohibition is a term of any contract relating to this drawing. Rights reserved under the Copyright Act 1956 as amended by the Design Copyright Act 1968.

