

Four fully extendable pull out drawers with 100mm deep removable pan inserts GN 1/1 size

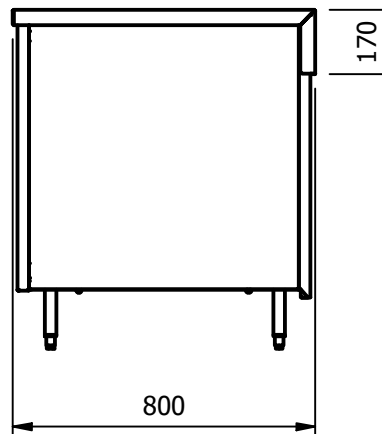
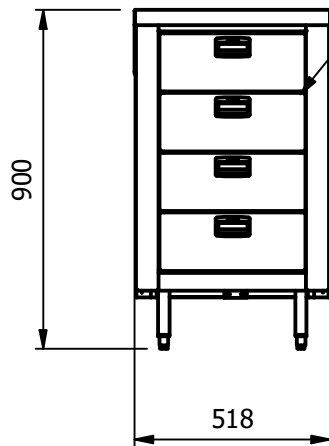

Moffat Specification

Drawer section with a solid stainless steel worktop

Dimensions

Width - 518mm
Depth - 800mm
Height - 900mm
Weight - 40kg

Capacity

Four drawers with removable inserts, 300mm x 500mm x 100mm

Materials

1.2mm 304 Grade St/ Steel Top & Supports
0.7mm 430 Grade St/ Steel Internal Structure

ALL SHEET METAL DIMENSIONS ARE I/S (INSIDE SIZES) (UNLESS OTHERWISE STATED)

ALL DIMENSIONS IN (mm), TOLERANCE = LINEAR ± 0.5mm, ANGULAR ± 0.5mm (OR AS STATED). ALL SHARP EDGES TO BE REMOVED FROM SHEET METAL PARTS

Product	COUNTERS			Product No						
Description	CDS-8				<small>© No reproduction or publication of this drawing may be made, and no article may be manufactured or assembled in accordance with this drawing without prior written consent. This prohibition is a term of any contract relating to this drawing. Rights reserved under the Copyright Act 1956 as amended by the Design Copyright Act 1968.</small>					
Material/Finish	Thickness			Desp/Date						
Legacy P/N	Weight	40kg		Quote No.	Dwg No.	CTRP-116753-1	Issue			
Client				SO Number	N/A		Drawn By	N.Raymen		
Client Project				Approved By			Date	28/06/2021		
E & R MOFFAT LTD, SEABEGS ROAD, BONNYBRIDGE, FK4 2BS, T: +44 (0)1324 812272, E: sales@ermoffat.co.uk, Web: www.ermoffat.co.uk						Scale	1 : 20	Sheet	1 / 4	A4

