

Basket platform 510mm x 510mm

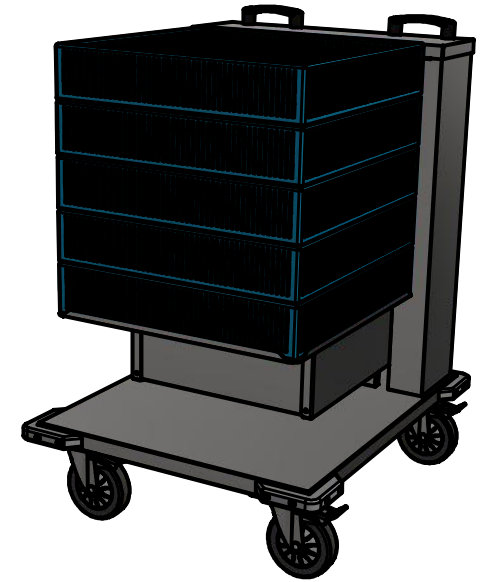

Moffat Specification

Dimensions

length - 755mm
 Depth - 635mm
 Height - 950mm
 Weight - 60kg

Features

Basket pickup area 510mm x 510mm

Materials

2.0mm 304 Grade St/Steel chassis
 1.2mm 430 grade St/Steel body
 Framework 25mm tube St/Steel

Installation

All swivel castors, two braked

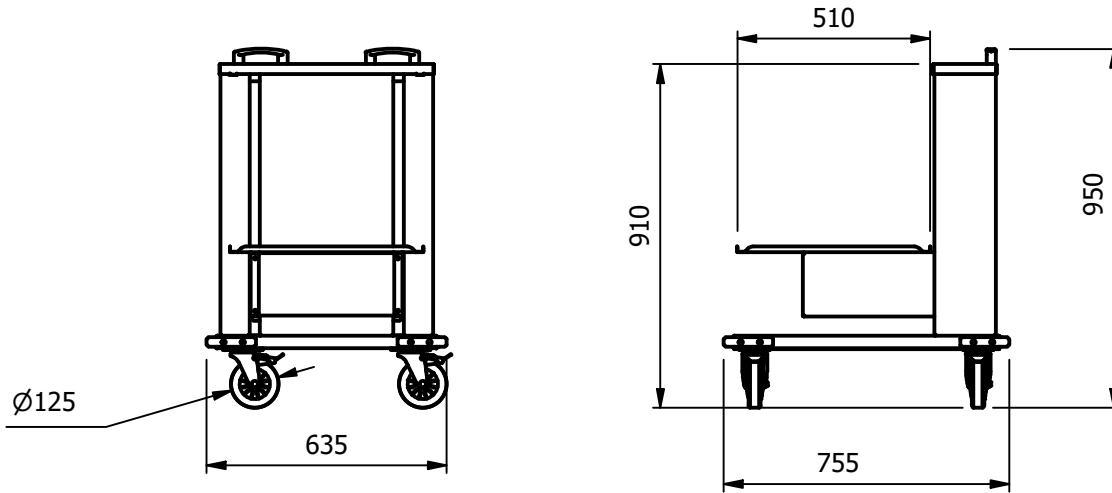

ALL SHEET METAL DIMENSIONS ARE I/S (INSIDE SIZES) (UNLESS OTHERWISE STATED)

ALL DIMENSIONS IN (mm), TOLERANCE = LINEAR ± 0.5mm, ANGULAR ± 0.5mm (OR AS STATED). ALL SHARP EDGES TO BE REMOVED FROM SHEET METAL PARTS

| | | | | | | | | |
|---|-----------|------|-------------|------------|--|-------------|-------|-----------|
| Product | TROLLEYS | | | Product No |  The Catering Equipment Company | | | |
| Description | CBD | | | | | | | |
| Material/Finish | Thickness | | Desp/Date | | <small>No reproduction or publication of this drawing may be made, and no article may be manufactured or assembled in accordance with this drawing without prior written consent. This prohibition is a term of any contract relating to this drawing. Rights reserved under the Copyright Act 1956 as amended by the Design Copyright Act 1968.</small> | | | |
| Legacy P/N | Weight | 60kg | Quote No. | | | | | |
| Client | | | SO Number | STD | Dwg No. | CTRA-080082 | Issue | |
| Client Project | | | Approved By | | Drawn By | N.Raymen | | |
| E & R MOFFAT LTD, SEABEGS ROAD, BONNYBRIDGE, FK4 2BS, T: +44 (0)1324 812272, E: sales@ermoffat.co.uk, Web: www.ermoffat.co.uk | | | | | Date | 15/09/2020 | | |
| | | | | | Scale | 1 : 20 | Sheet | 1 / 2 |
| | | | | | | | | A4 |