

**Moffat Specification**

Hot Top  
 Anodised alloy top  
 Thermostatic rotary controlled between 30 to 110°C

Dimensions  
 Width - 1086mm  
 Depth - 567mm  
 Height - 544mm  
 Weight - 17kg

Power Rating  
 1.69kw  
 complete with a 2m long cord set & 13amp plug

Materials  
 0.7mm 430 Grade St/Steel  
 1.2mm Galvanized Steel Ancillary Parts  
 2.0mm Anodised alloy top

Installation  
 Tabletop

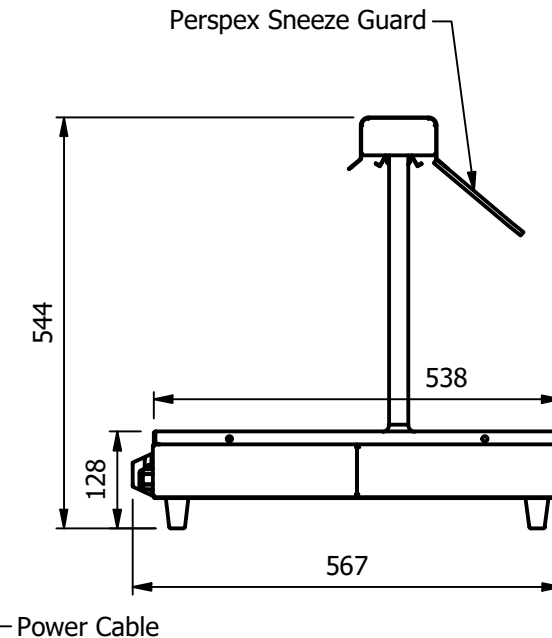
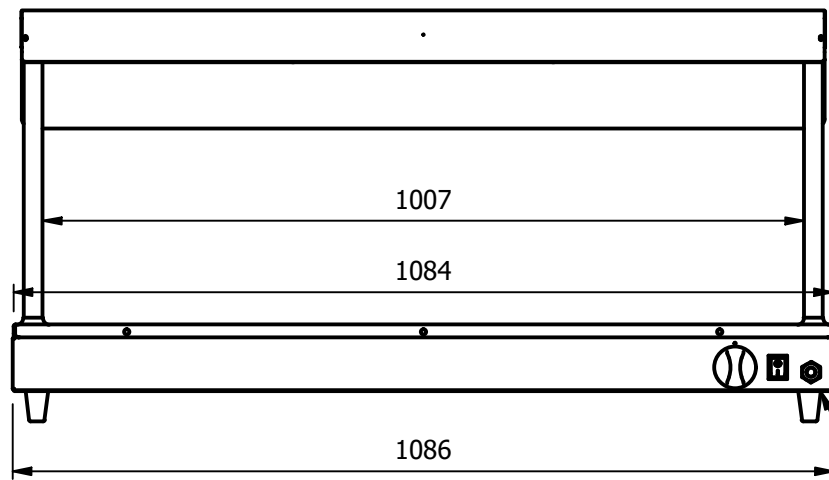

ALL SHEET METAL DIMENSIONS ARE I/S (INSIDE SIZES) (UNLESS OTHERWISE STATED)

ALL DIMENSIONS IN (mm), TOLERANCE = LINEAR ± 0.5mm, ANGULAR ± 0.5mm (OR AS STATED). ALL SHARP EDGES TO BE REMOVED FROM SHEET METAL PARTS

Product	BEL TOPS				 The Catering Equipment Company	
Description	BTG3					
Material/Finish	Thickness	Weight	Desp/Date	Quote No.	Dwg No.	
		17kg			BEL-004870	
Client			SO Number	STD	Drawn By	
Client Project			Approved By		ABB	
E & R MOFFAT LTD, SEABEGS ROAD, BONNYBRIDGE, FK4 2BS, T: +44 (0)1324 812272, E: sales@ermoffat.co.uk, Web: www.ermoffat.co.uk					Date	24/04/2018
					Scale	1 : 10
					Sheet	1 / 2
						<b>A4</b>

© No reproduction or publication of this drawing may be made, and no article may be manufactured or assembled in accordance with this drawing without prior written consent. This prohibition is a term of any contract relating to this drawing. Rights reserved under the Copyright Act 1956 as amended by the Design Copyright Act 1968.