

## Overview

Mobile open racks for storage and transporting Bakers sheets / trays. Ideal for maximising storage capacity and easy handling in bakeries, kitchens and general food service facilities. Fully welded stainless steel construction. Complete with 125mm diameter. Swivel castors two with brakes. The robust compact mobile design provides sturdy and hygienic conveyance in a busy bakery.

The unique space saving "Z" shape allows multiple nesting when racks are empty.

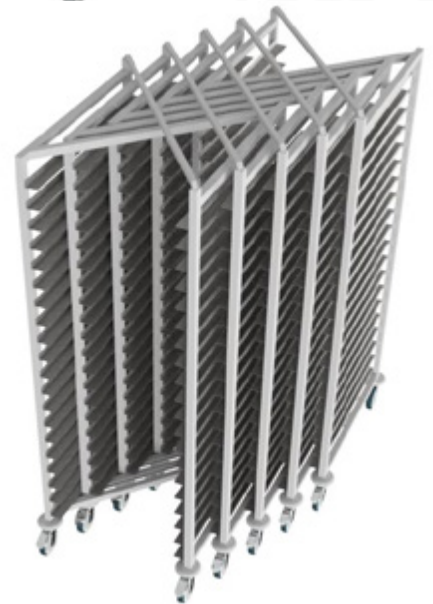

## Key Features:

- Zee racks designed to nest into each other when empty to enable five racks to occupy the area normally occupied by two
- Designed to take bakers sheets / trays 600mm x 400mm.
- Support runners manufactured from 1.2mm stainless steel.
- 82mm shelf pitch.
- Ideal for receiving, transporting, preparing, and storing.
- Uprights & diagonal ties in 30mm square section steel (type 304) welded together to form 'Z' shaped framework
- Compact heavy duty fully welded construction.
- Complete with 125mm dia. Swivel castors 2 with brakes.

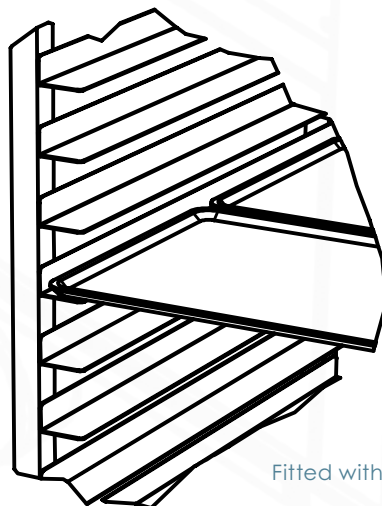

Fitted with large runners to suit trays





Model	Capacity 600mm x 400mm type trays	Weight (kg)	L x W x H (mm)
BKZEE	40	30	888 x 746 x 1946

Compact space saving design  
Example of 5 racks stacked together

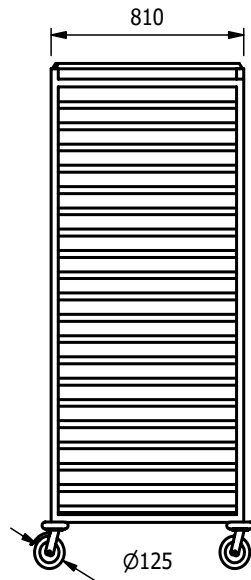
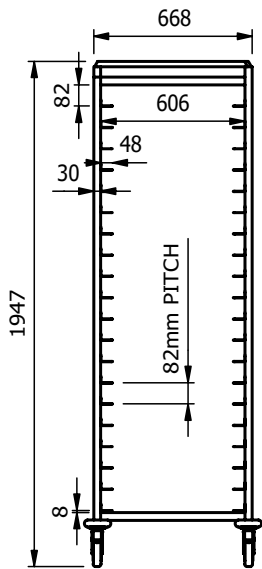
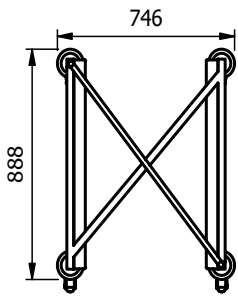
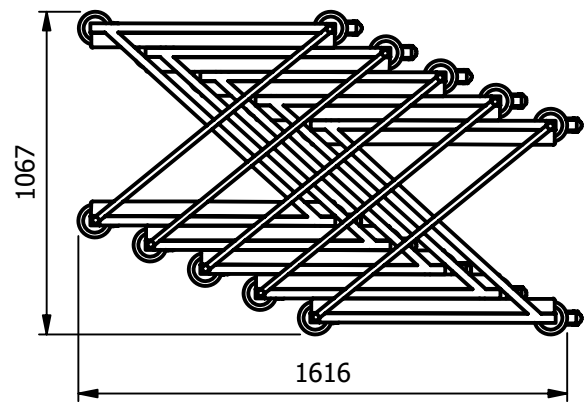

E&R Moffat Ltd.  
Bonnybridge  
FK4 2BS  
Scotland

Find us on:



www.ermoffat.co.uk  
+44 (0) 1324 812272  
sales@ermoffat.co.uk