

Large support runners for trays

A ( 0.08 : 1 )

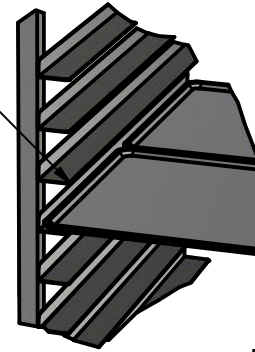

Revolving buffers

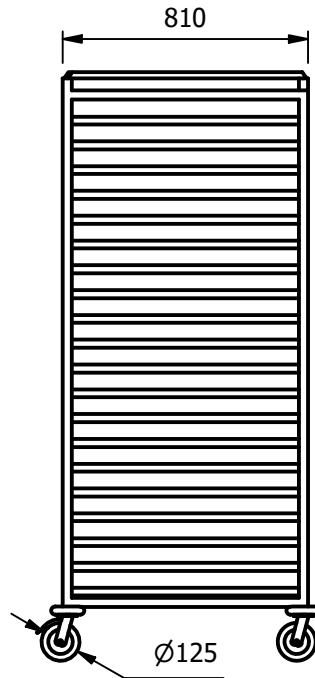
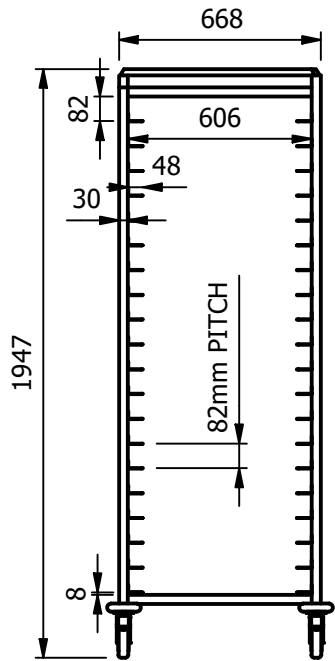
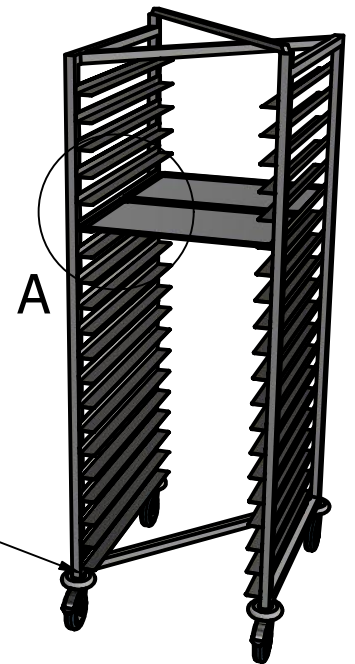

Compact space saving design  
example of 5 racks stacked together

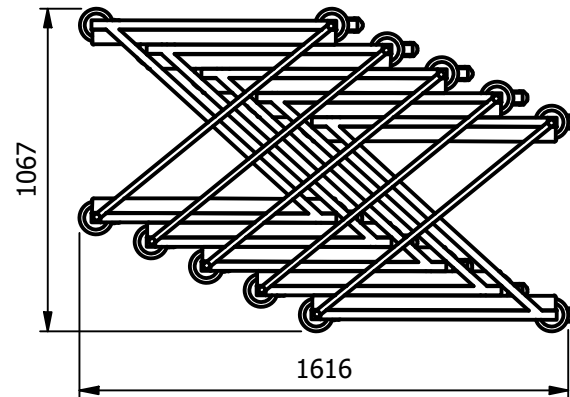

**Moffat Specification**

Dimensions  
length - 888mm  
Depth - 746mm  
Height - 1947mm  
Weight - 30kg

Capacity  
40 x 600mm x 400mm bakers sheet type trays

Shelf pitch 82mm

Materials  
1.2mm 304 Grade St/ Steel 30 x 30 tube frame

Installation  
All swivel castors, two braked

ALL SHEET METAL DIMENSIONS ARE I/S (INSIDE SIZES) (UNLESS OTHERWISE STATED)

ALL DIMENSIONS IN (mm), TOLERANCE = LINEAR ± 0.5mm, ANGULAR ± 0.5mm (OR AS STATED). ALL SHARP EDGES TO BE REMOVED FROM SHEET METAL PARTS

Product	FABRICATION			Product No	 The Catering Equipment Company
Description	BKZEE				
Material/Finish	30mm SQ 304 TUBE	Thickness		Desp/Date	No reproduction or publication of this drawing may be made, and no article may be manufactured or assembled in accordance with this drawing without prior written consent. This prohibition is a term of any contract relating to this drawing. Rights reserved under the Copyright Act 1956 as amended by the Design Copyright Act 1968.
Legacy P/N		Weight	30kg	Quote No.	
Client				SO Number	STD
Client Project				Approved By	
E & R MOFFAT LTD, SEABEGS ROAD, BONNYBRIDGE, FK4 2BS, T: +44 (0)1324 812272, E: sales@ermoffat.co.uk, Web: www.ermoffat.co.uk					Dwg No. MRKA-074657 Drawn By N.Raymen Date 17/06/2020 Scale 1 : 25
					Issue - Sheet 1 / 1 A4