

Three holding drawers

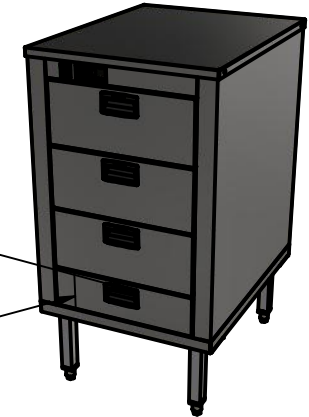

Pull out humidity water tray

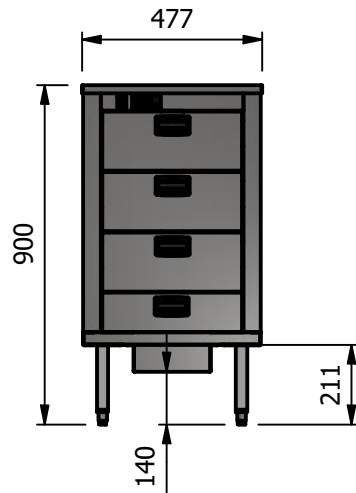

Fan Heater

**Moffat Specification**

Dimensions

Width - 477mm  
 Depth - 610mm  
 Height - 900mm  
 Weight - 32kg

3 perforated drawers

Inside dimension of each drawer  
 Length - 515mm  
 Width - 298mm  
 Depth - 100mm  
 Total Capacity - 15.3 Litres

Power Rating

0.9kw  
 complete with a 2m long cord set & 13amp plug

Materials

0.7mm 430 Grade St/Steel inner panels  
 1.2mm 304 Grade St/ Steel structure  
 1.2mm 430 Grade St Steel Ancillary Parts

ALL SHEET METAL DIMENSIONS ARE I/S (INSIDE SIZES) (UNLESS OTHERWISE STATED)

ALL DIMENSIONS IN (mm), TOLERANCE = LINEAR ± 0.5mm, ANGULAR ± 0.5mm (OR AS STATED). ALL SHARP EDGES TO BE REMOVED FROM SHEET METAL PARTS

Product	COUNTERS			Product No							
Description	BKRW3										
Material/Finish	Thickness			Desp/Date							
Legacy P/N	Weight	32kg		Quote No.	Dwg No.		CTRA-079114		Issue		
Client				SO Number	STD		Drawn By	N.Raymen			
Client Project				Approved By			Date	09/09/2020			
E & R MOFFAT LTD, SEABEGS ROAD, BONNYBRIDGE, FK4 2BS, T: +44 (0)1324 812272, E: sales@ermoffat.co.uk, Web: www.ermoffat.co.uk							Scale	1 : 20	Sheet	1 / 2	<b>A4</b>

No reproduction or publication of this drawing may be made, and no article may be manufactured or assembled in accordance with this drawing without prior written consent. This prohibition is a term of any contract relating to this drawing. Rights reserved under the Copyright Act 1956 as amended by the Design Copyright Act 1968.

