

Large support runners for trays

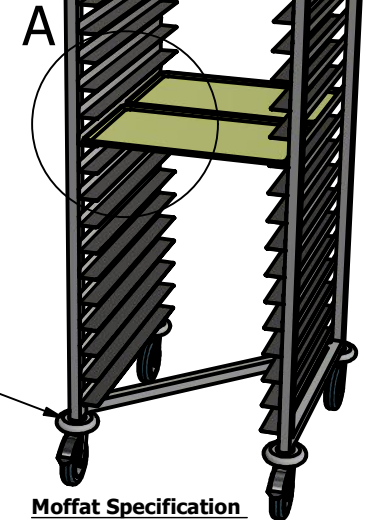
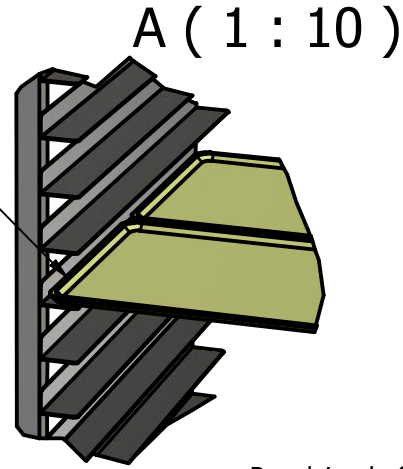

Revolving buffers

Moffat Specification

Dimensions

length - 750mm
Depth - 680mm
Height - 1705mm
Weight - 28kg

Capacity

19 x 2/1 Gastronorm type trays
or
38 x 1/1 Gastronorm type trays

Shelf pitch 72mm

Materials

1.2mm 304 Grade St/ Steel 30 x 30 tube frame

Installation

All swivel castors, two braked

Compact space saving design
example of 5 racks stacked together

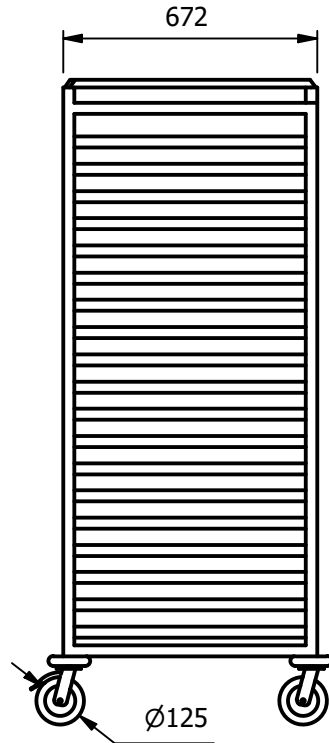
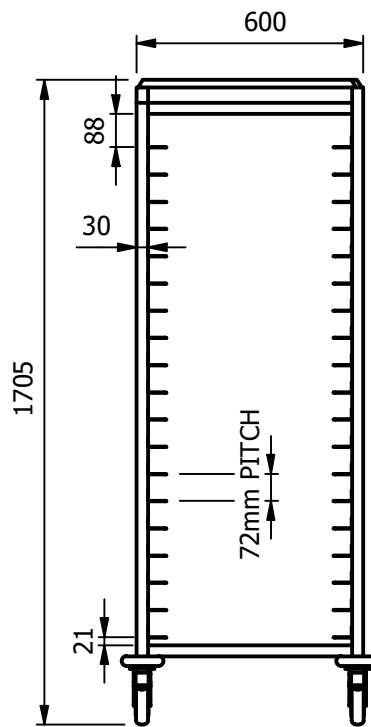
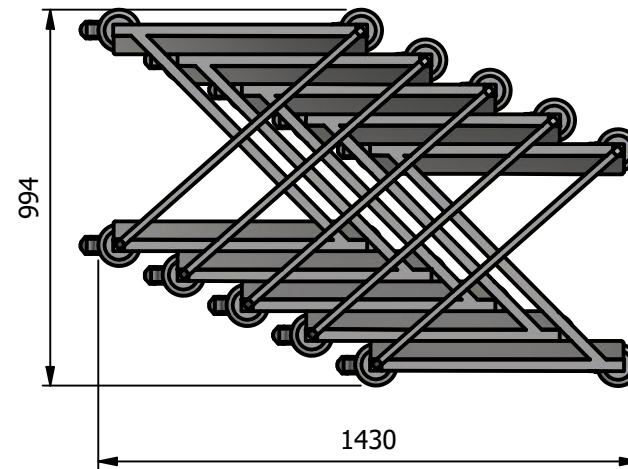

ALL SHEET METAL DIMENSIONS ARE I/S (INSIDE SIZES) (UNLESS OTHERWISE STATED)

ALL DIMENSIONS IN (mm), TOLERANCE = LINEAR ± 0.5mm, ANGULAR ± 0.5mm (OR AS STATED). ALL SHARP EDGES TO BE REMOVED FROM SHEET METAL PARTS

Product	FABRICATION			Product No	 The Catering Equipment Company		
Description	ZMT						
Material/Finish	30mm SQ 304 TUBE	Thickness		Desp/Date			
Legacy P/N		Weight	28kg	Quote No.			
Client				SO Number	STD		
Client Project				Approved By			
E & R MOFFAT LTD, SEABEGS ROAD, BONNYBRIDGE, FK4 2BS, T: +44 (0)1324 812272, E: sales@ermoffat.co.uk, Web: www.ermoffat.co.uk					Dwg No.	MRKA-075147	Issue
					Drawn By	N.Raymen	-
					Date	17/06/2020	
					Scale	1 : 20	Sheet 1 / 2
							A4