

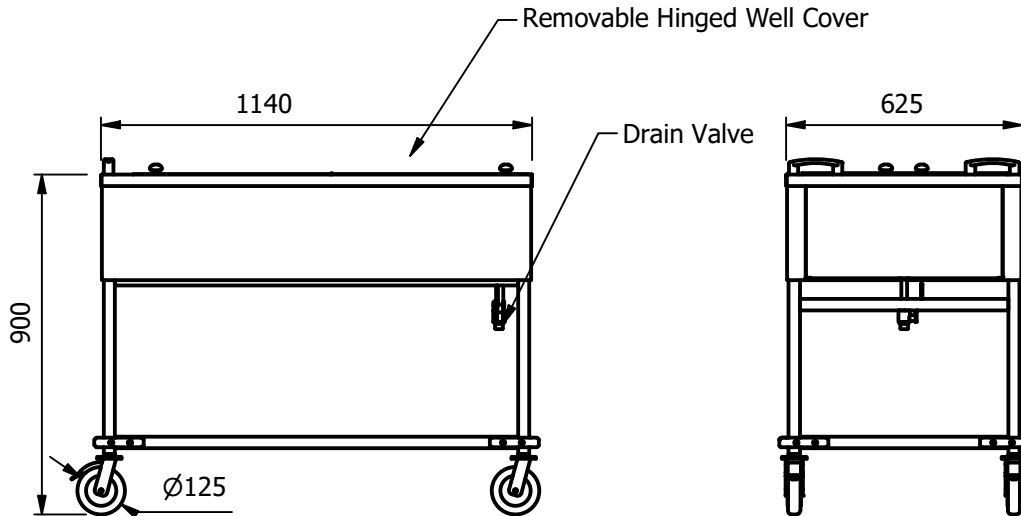

Moffat Polar Plates keep food chilled for 2 to 3 hours. Before use, the Polar Plates are charged for 8 to 12 hours in a deep freeze.

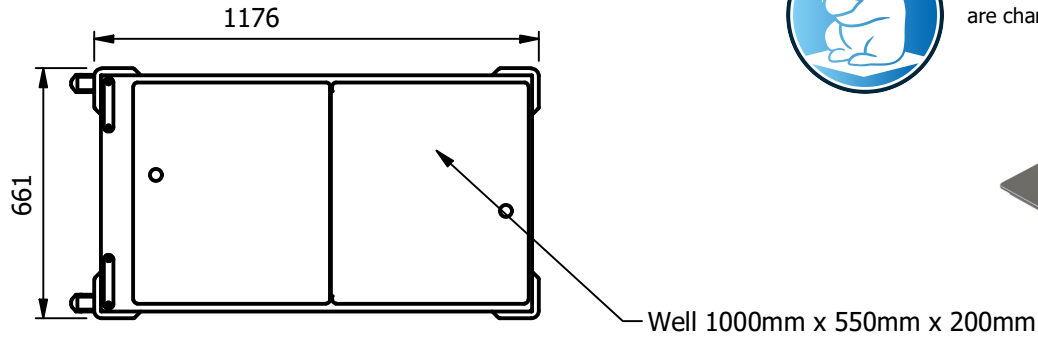

**Moffat Specification**

Cold Polar Well  
complete with a drain valve, and a removable hinged well cover

Dimensions  
Width - 1176mm  
Depth - 661mm  
Height - 940mm (Worktop 900mm)  
Weight - 44kg

Capacity of Well  
1000mm x 550mm x 200mm deep  
Can accommodate Three GN1/1 pans up to 150mm deep

Materials  
1.2mm 304 Grade St/ Steel Top & Supports  
0.7mm 430 Grade St/ Steel Outer Structure

Installation  
All swivel castors, two braked

ALL SHEET METAL DIMENSIONS ARE I/S (INSIDE SIZES) (UNLESS OTHERWISE STATED)

ALL DIMENSIONS IN (mm), TOLERANCE = LINEAR ± 0.5mm, ANGULAR ± 0.5mm (OR AS STATED). ALL SHARP EDGES TO BE REMOVED FROM SHEET METAL PARTS

Product	TROLLEYS			Product No	 The Catering Equipment Company			
Description	VMPW3							
Material/Finish	Thickness		Desp/Date		<small>No reproduction or publication of this drawing may be made, and no article may be manufactured or assembled in accordance with this drawing without prior written consent. This prohibition is a term of any contract relating to this drawing. Rights reserved under the Copyright Act 1956 as amended by the Design Copyright Act 1968.</small>			
Legacy P/N	Weight	44kg	Quote No.					
Client			SO Number	STD	Dwg No.	VCP-077891	Issue	
Client Project			Approved By		Drawn By	ABB		
E & R MOFFAT LTD, SEABEGS ROAD, BONNYBRIDGE, FK4 2BS, T: +44 (0)1324 812272, E: sales@ermoffat.co.uk, Web: www.ermoffat.co.uk					Date	04/08/2020		
					Scale	1 : 20	Sheet	1 / 2
								<b>A4</b>