

Moffat Specification

- Cold contact chilled well complete with a drain valve, removable perforated base trays and a removable hinged well cover

- Dimensions
 Width - 1176mm
 Depth - 661mm
 Height - 940mm (Worktop 900mm)
 Weight - 74kg

- Capacity of Well
 1000mm x 550mm x 200mm deep
 Can accommodate Three GN1/1 pans up to 150mm deep

- Power Rating
 0.75kw
 complete with a 2m long cord set & 13amp plug

- Materials
 1.2mm 304 Grade St/ Steel Top & Supports
 0.7mm 430 Grade St/ Steel Outer Structure

- Installation
 All swivel castors, two braked

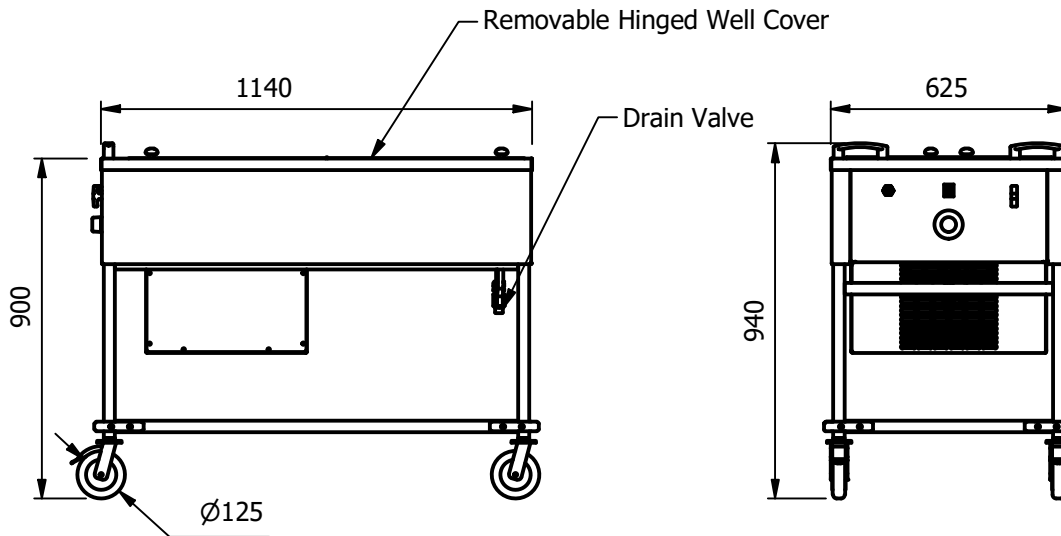

ALL SHEET METAL DIMENSIONS ARE I/S (INSIDE SIZES) (UNLESS OTHERWISE STATED)

ALL DIMENSIONS IN (mm), TOLERANCE = LINEAR ± 0.5mm, ANGULAR ± 0.5mm (OR AS STATED). ALL SHARP EDGES TO BE REMOVED FROM SHEET METAL PARTS

Product	TROLLEYS			Product No	 The Catering Equipment Company				
Description	VMCW3								
Material/Finish	Thickness		Desp/Date		<small>No reproduction or publication of this drawing may be made, and no article may be manufactured or assembled in accordance with this drawing without prior written consent. This prohibition is a term of any contract relating to this drawing. Rights reserved under the Copyright Act 1956 as amended by the Design Copyright Act 1968.</small>				
Legacy P/N	Weight	74kg	Quote No.						
Client			SO Number	STD	Dwg No.	VCP-077960	Issue		
Client Project			Approved By		Drawn By	ABB	-		
E & R MOFFAT LTD, SEABEGS ROAD, BONNYBRIDGE, FK4 2BS, T: +44 (0)1324 812272, E: sales@ermoffat.co.uk, Web: www.ermoffat.co.uk					Date	04/08/2020			
					Scale	1 : 20	Sheet	1 / 2	A4