

Sahara Fan Model SF319



Moffat Specification

Bainmarie well

Dry heat

The open top with raised lip is designed to hold Gastronorm pans and heats via a fan heating cell fitted inside the well.

Dry Heat

Fan Assisted Hotcupboard

Dimensions

Width - 1506mm

Depth - 661mm

Height - 940mm (work top 900mm)

Weight - 56kg

Capacity of Bainmarie

Four GN1/1 pans up to 150mm deep

[Note:-pans are not supplied, available at extra cost]

Power Rating

1.9kw

complete with a 2m long cord set & 13amp plug

Removable Fan heating System Sahara Fan Model SF319

Materials

1.2mm 304 Grade St/ Steel Top & Supports

0.7mm 430 Grade St/ Steel Internal Structure

Installation

All swivel castors, two braked

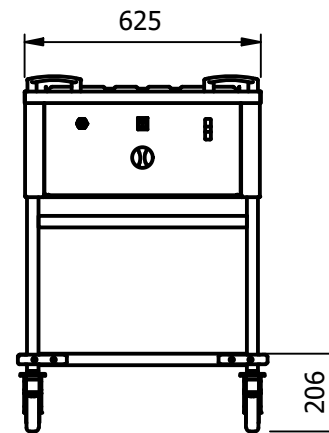
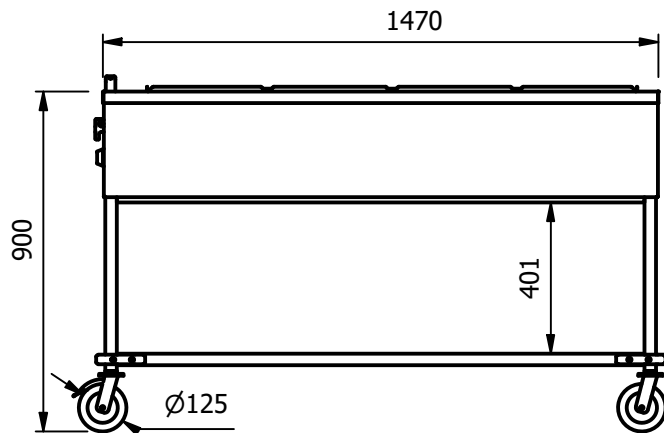

ALL SHEET METAL DIMENSIONS ARE I/S (INSIDE SIZES) (UNLESS OTHERWISE STATED)

ALL DIMENSIONS IN (mm), TOLERANCE = LINEAR ± 0.5mm, ANGULAR ± 0.5mm (OR AS STATED). ALL SHARP EDGES TO BE REMOVED FROM SHEET METAL PARTS

Product	VERSICARTE			Product No							
Description	VMBM4										
Material/Finish	Thickness			Desp/Date							
Legacy P/N	Weight	56kg		Quote No.							
Client				SO Number	STD		Dwg No.	VCP-077841	Issue		
Client Project				Approved By			Drawn By	N.Raymen	-		
							Date	04/08/2020			
E & R MOFFAT LTD, SEABEGS ROAD, BONNYBRIDGE, FK4 2BS, T: +44 (0)1324 812272, E: sales@ermoffat.co.uk, Web: www.ermoffat.co.uk							Scale	1 : 20	Sheet	1 / 2	A4

No reproduction or publication of this drawing may be made, and no article may be manufactured or assembled in accordance with this drawing without prior written consent. This prohibition is a term of any contract relating to this drawing. Rights reserved under the Copyright Act 1956 as amended by the Design Copyright Act 1968.

