

Sahara Fan Model SF309

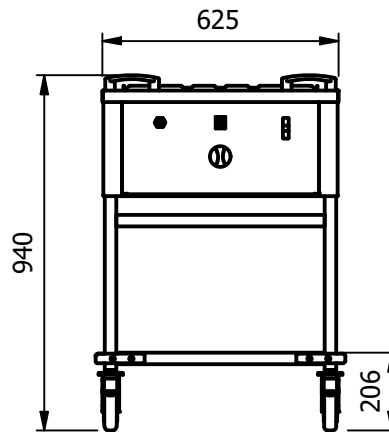
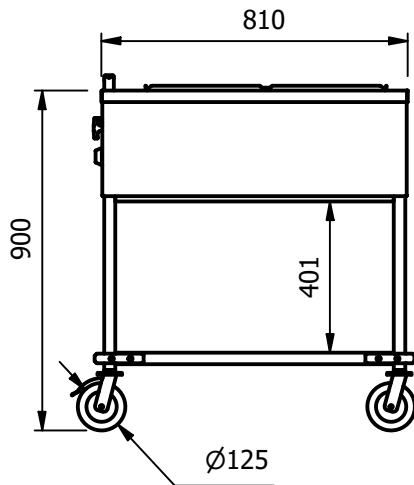
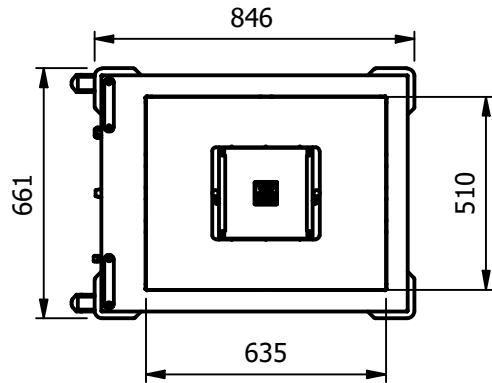

**Moffat Specification**

Bainmarie well

Dry heat

The open top with raised lip is designed to hold Gastronorm pans and heats via a fan heating cell fitted inside the well.

Dry Heat

Fan Assisted Hotcupboard

Dimensions

Width - 846mm

Depth - 661mm

Height - 940mm (Worktop 900mm)

Weight - 33kg

Capacity of Bainmarie

Two GN1/1 pans up to 150mm deep

[Note:-pans are not supplied, available at extra cost]

Power Rating

0.9kw

complete with a 2m long cord set & 13amp plug

Removable Fan heating System Sahara Fan Model SF309

Materials

1.2mm 304 Grade St/ Steel Top & Supports

0.7mm 430 Grade St/ Steel Internal Structure

Installation

All swivel castors, two braked

ALL SHEET METAL DIMENSIONS ARE I/S (INSIDE SIZES) (UNLESS OTHERWISE STATED)

ALL DIMENSIONS IN (mm), TOLERANCE = LINEAR ± 0.5mm, ANGULAR ± 0.5mm (OR AS STATED). ALL SHARP EDGES TO BE REMOVED FROM SHEET METAL PARTS

Product	VERSICARTE		Product No			<p>The Catering Equipment Company</p>				
Description	VMBM2									
Material/Finish	Thickness		Desp/Date			<small>No reproduction or publication of this drawing may be made, and no article may be manufactured or assembled in accordance with this drawing without prior written consent. This prohibition is a term of any contract relating to this drawing. Rights reserved under the Copyright Act 1956 as amended by the Design Copyright Act 1968.</small>				
Legacy P/N	Weight	33kg	Quote No.				Dwg No.	VCP-076342	Issue	
Client			SO Number	STD		Drawn By	N.Raymen			
Client Project			Approved By			Date	04/08/2020			
E & R MOFFAT LTD, SEABEGS ROAD, BONNYBRIDGE, FK4 2BS, T: +44 (0)1324 812272, E: sales@ermoffat.co.uk, Web: www.ermoffat.co.uk						Scale	1 : 20	Sheet	1 / 2	<b>A4</b>