

NOTE:- Serving height for children up to 12 years of age.
 This model is available with a work top height of 800mm
 Trayslide height of 773mm.
 Please add "B" to the end of the product code.

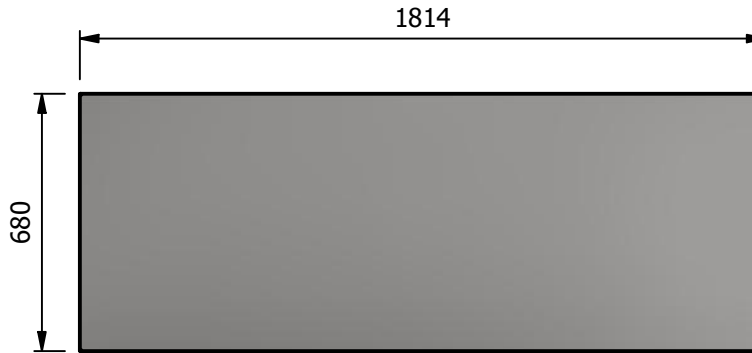
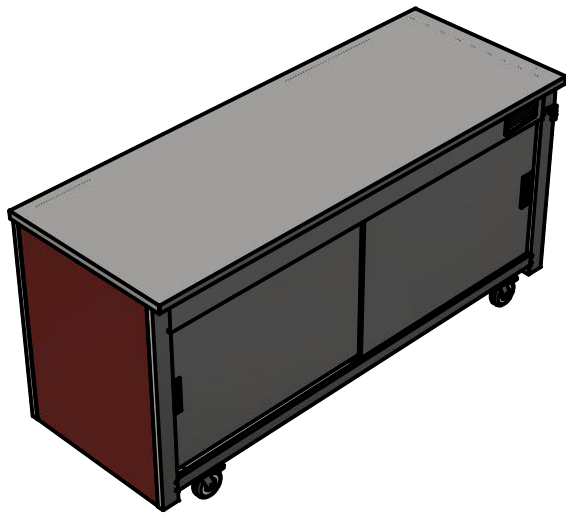

Moffat Specification

Solid Stainless Steel Worktop provides a clean serving area.

Dimensions

Width - 1814mm
 Depth - 680mm
 Height - 900mm
 Weight - 75kg

Capacity of Cupboard [usable inside space]

Width - 1679mm
 Depth - 555mm
 Usable Height Bottom shelf - 204mm
 Usable Height Top Shelf - 245mm

228 off 10" plates stacked
 or
 10 off 1/1GN pans side by side 150mm deep 5 on top 5 on bottom

Materials

1.2mm 304 Grade St/ Steel Top & Supports
 0.7mm 430 Grade St/ Steel Internal Structure
 GN 1/1 Grid Shelves with 30mm x 30mm tube supports

Installation

All swivel castors, two braked

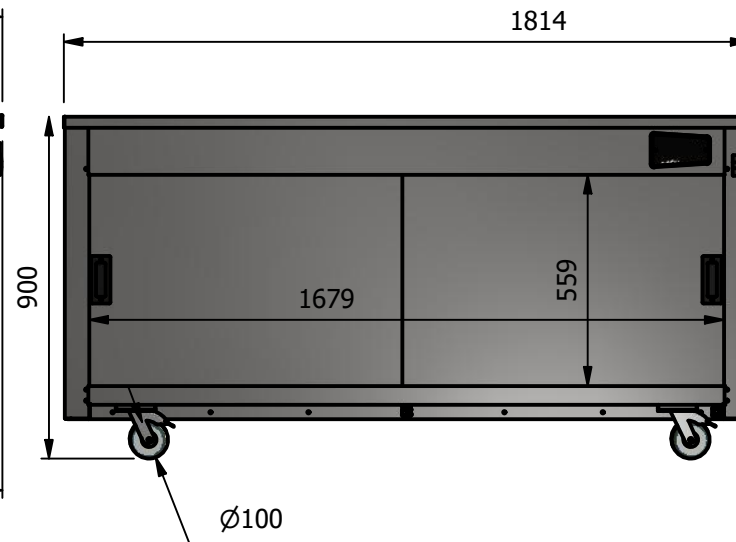
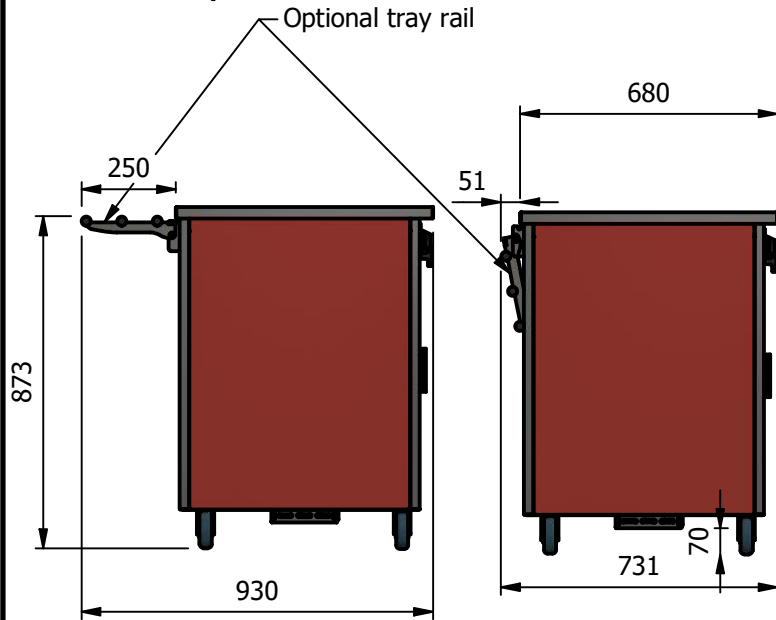

ALL SHEET METAL DIMENSIONS ARE I/S (INSIDE SIZES) (UNLESS OTHERWISE STATED)

ALL DIMENSIONS IN (mm), TOLERANCE = LINEAR ± 0.5mm, ANGULAR ± 0.5mm (OR AS STATED). ALL SHARP EDGES TO BE REMOVED FROM SHEET METAL PARTS

Product	VERSICARTE			Product No	N/A		
Description	*** VC5SC ***						
Material/Finish	Thickness			Desp/Date			
Legacy P/N	Weight	75kg		Quote No.			
Client				SO Number	STANDARD		
Client Project				Approved By			
				Dwg No.	VCP-060376		Issue
				Drawn By	ABB		-
				Date	28/10/2019		
E & R MOFFAT LTD, SEABEGS ROAD, BONNYBRIDGE, FK4 2BS, T: +44 (0)1324 812272, E: sales@ermoffat.co.uk, Web: www.ermoffat.co.uk				Scale	1 : 20		Sheet 1 / 2 A4

No reproduction or publication of this drawing may be made, and no article may be manufactured or assembled in accordance with this drawing without prior written consent. This prohibition is a term of any contract relating to this drawing. Rights reserved under the Copyright Act 1956 as amended by the Design Copyright Act 1968.

