

NOTE:- Serving height for children up to 12 years of age.  
 This model is available with a work top height of 800mm  
 and a Trayside height of 773mm.  
 Please add "B" to the end of the product code.

**Moffat Specification**

Solid hot Top

The Stainless Steel recessed top provides a clean hot serving area, via a solid state element fitted internally below, additional excess residual hot air from the hot cupboard is also used to maintain temperature which gives energy saving efficiency.

Dry Heat

Fan Assisted Hotcupboard

Dimensions

Width - 1158mm  
 Depth - 680mm  
 Height - 900mm  
 Weight - 67kg



Sahara Fan Model SF309

Area of hot top

999mm x 522mm

Capacity of Hot Cupboard [usable inside space]

Width - 1023mm  
 Depth - 555mm  
 Usable Height Bottom shelf - 204mm  
 Usable Height Top Shelf - 245mm

35 covers & meals [10" plated meals stacked using plate covers]  
 or  
 133 off 10" plates stacked for heating  
 or  
 6 off 1/1GN pans side by side 150mm deep 3 on top 3 on bottom

Power Rating

1.90kw with no gantry, 2.34Kw with heated gantry.  
 complete with a 2m long cord set & 13amp plug  
 Removable Fan heating System Sahara Fan Model SF309

Materials

1.2mm 304 Grade St/ Steel Top & Supports  
 0.7mm 430 Grade St/ Steel Internal Structure  
 GN 1/1 Grid Shelves with 30mm x 30mm tube supports

Installation

All swivel castors, two braked

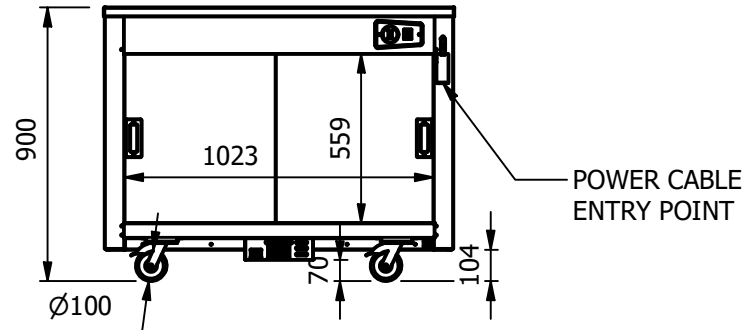
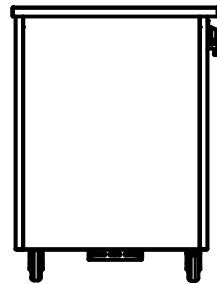
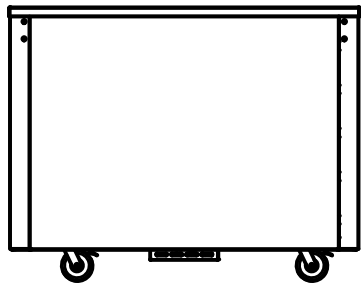
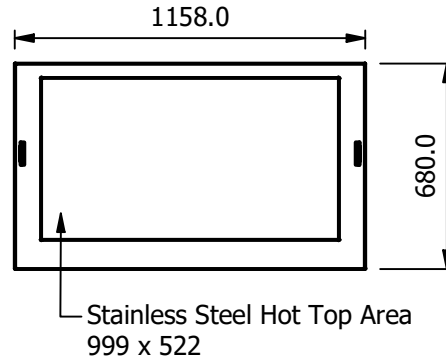

ALL SHEET METAL DIMENSIONS ARE I/S (INSIDE SIZES) (UNLESS OTHERWISE STATED)

ALL DIMENSIONS IN (mm), TOLERANCE = LINEAR ± 0.5mm, ANGULAR ± 0.5mm (OR AS STATED). ALL SHARP EDGES TO BE REMOVED FROM SHEET METAL PARTS

|   |                |      |  |             |            |  |                       |  |
|---|----------------|------|--|-------------|------------|--|-----------------------|--|
| Product   | VERSICARTE     |      |  | Product No  | N/A        |  |                       |  |
| Description   | *** VC3HTS *** |      |  |             |            |  |                       |  |
| Material/Finish   | Thickness      |      |  | Desp/Date   |            |  |                       |  |
| Legacy P/N  | Weight         | 67kg |  | Quote No.   |            |  |                       |  |
| Client  |                |      |  | SO Number   | STANDARD   |  |                       |  |
| Client Project  |                |      |  | Approved By |            |  |                       |  |
|   |                |      |  | Dwg No.     | VCP-072938 |  | Issue                 |  |
|   |                |      |  | Drawn By    | ABB        |  | -                     |  |
|   |                |      |  | Date        | 03/07/2023 |  |                       |  |
| E & R MOFFAT LTD, SEABEGS ROAD, BONNYBRIDGE, FK4 2BS, T: +44 (0)1324 812272, E: sales@ermoffat.co.uk, Web: www.ermoffat.co.uk |                |      |  | Scale       | 1 : 25     |  | Sheet 1 / 1 <b>A4</b> |  |