

NOTE:- Serving height for children up to 12 years of age.
 This model is available with a work top height of 800mm
 Trayslide height of 773mm.
 Please add "B" to the end of the product code.

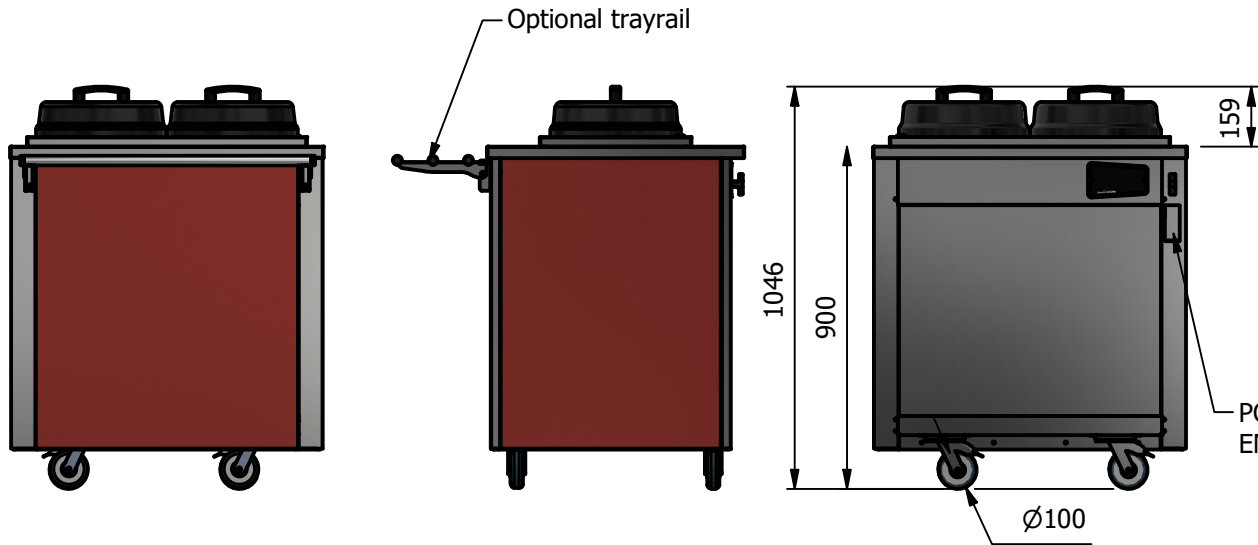
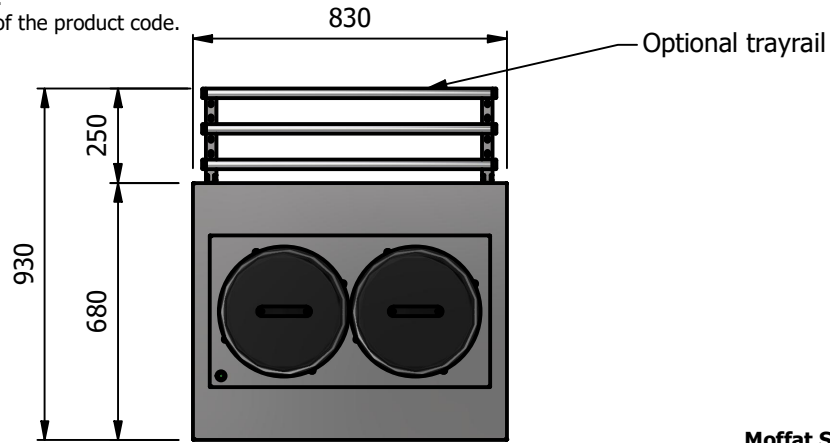

Moffat Specification

Fitted with double tube pop up plate dispenser.
 Each Tube has four adjustable guide rods to enable it to take various size plates from 8"-12" (205mm-305mm) diameter with a maximum capacity of around 65 plates per tube.

Dimensions
 Width - 830mm
 Depth - 680mm
 Height - 1046mm
 Weight - 58kg

Power Rating
 1.20kw
 complete with a 2m long cord set & 13amp plug

Materials
 1.2mm 304 Grade St/ Steel Top & Supports
 0.7mm 430 Grade St/ Steel Internal Structure
 GN 1/1 Grid Shelves with 30mm x 30mm tube supports

Installation
 All swivel castors, two braked

ALL SHEET METAL DIMENSIONS ARE I/S (INSIDE SIZES) (UNLESS OTHERWISE STATED)

ALL DIMENSIONS IN (mm), TOLERANCE = LINEAR ± 0.5mm, ANGULAR ± 0.5mm (OR AS STATED). ALL SHARP EDGES TO BE REMOVED FROM SHEET METAL PARTS

Product	VERSICARTE		Product No	N/A		 The Catering Equipment Company				
Description	*** VC2PDH ***									
Material/Finish	Thickness		Desp/Date			<small>No reproduction or publication of this drawing may be made, and no article may be manufactured or assembled in accordance with this drawing without prior written consent. This prohibition is a term of any contract relating to this drawing. Rights reserved under the Copyright Act 1956 as amended by the Design Copyright Act 1968.</small>				
Legacy P/N	Weight	58kg	Quote No.	Dwg No.	VCP-071084		Issue			
Client			SO Number	STANDARD		Drawn By	ABB			
Client Project			Approved By			Date	28/10/2019			
E & R MOFFAT LTD, SEABEGS ROAD, BONNYBRIDGE, FK4 2BS, T: +44 (0)1324 812272, E: sales@ermoffat.co.uk, Web: www.ermoffat.co.uk						Scale	1 : 20	Sheet	1 / 2	A4