

NOTE:- Serving height for children up to 12 years of age.  
 This model is available with a work top height of 800mm  
 Trayslide height of 773mm.  
 Please add "B" to the end of the product code.

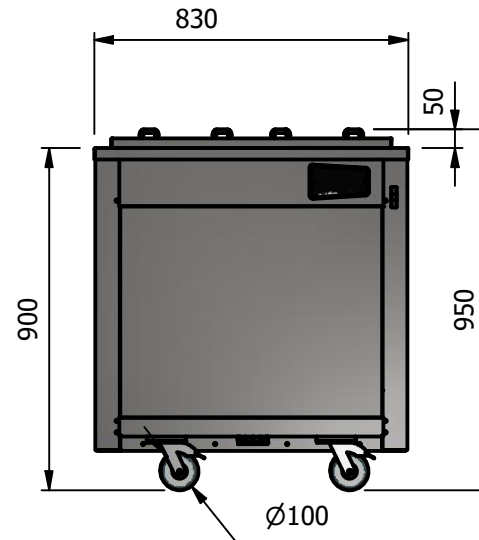
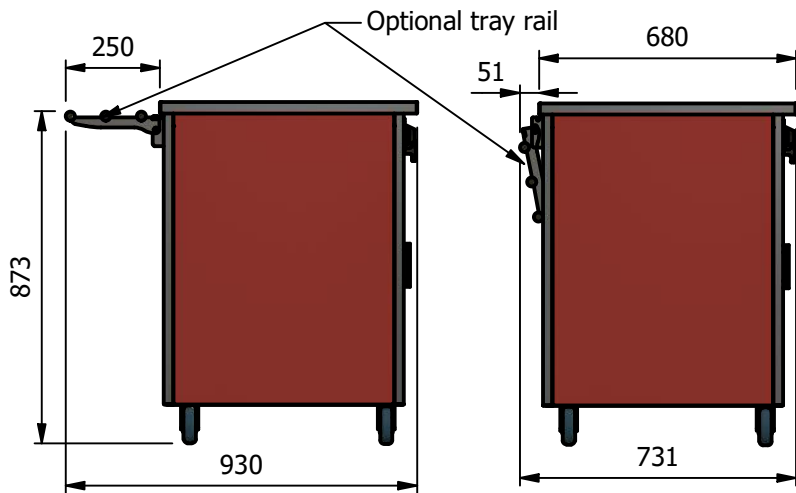
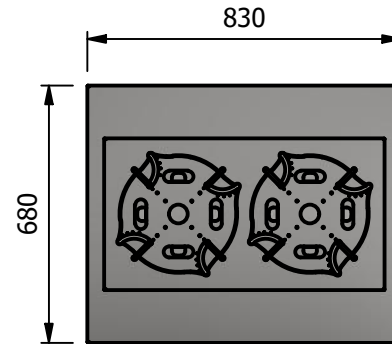

**Moffat Specification**

Fitted with double tube pop up plate dispenser.  
 Each Tube has four adjustable guide rods to enable it to take various size plates from 8"-12" (205mm-305mm) diameter with a maximum capacity of around 65 plates per tube.

Dimensions  
 Width - 830mm  
 Depth - 680mm  
 Height - 950mm  
 Weight - 57kg

Materials  
 1.2mm 304 Grade St/ Steel Top & Supports  
 0.7mm 430 Grade St/ Steel Internal Structure  
 GN 1/1 Grid Shelves with 30mm x 30mm tube supports

Installation  
 All swivel castors, two braked

ALL SHEET METAL DIMENSIONS ARE I/S (INSIDE SIZES) (UNLESS OTHERWISE STATED)

ALL DIMENSIONS IN (mm), TOLERANCE = LINEAR ± 0.5mm, ANGULAR ± 0.5mm (OR AS STATED). ALL SHARP EDGES TO BE REMOVED FROM SHEET METAL PARTS

Product	VERSICARTE			Product No	N/A		
Description	*** VC2PDA ***			<small>© No reproduction or publication of this drawing may be made, and no article may be manufactured or assembled in accordance with this drawing without prior written consent. This prohibition is a term of any contract relating to this drawing. Rights reserved under the Copyright Act 1956 as amended by the Design Copyright Act 1968.</small>			
Material/Finish	Thickness		Desp/Date				
Legacy P/N	Weight	57kg	Quote No.	Dwg No.	VCP-071148	Issue	
Client			SO Number	STANDARD	Drawn By	ABB	-
Client Project			Approved By		Date	28/10/2019	
E & R MOFFAT LTD, SEABEGS ROAD, BONNYBRIDGE, FK4 2BS, T: +44 (0)1324 812272, E: sales@ermoffat.co.uk, Web: www.ermoffat.co.uk					Scale	1 : 20	Sheet 1 / 2 <b>A4</b>