

Moffat Specification

Solid hot Top

The Stainless Steel recessed top provides a clean hot serving area, via a solid state element fitted internally below, additional excess residual hot air from the hot cupboard is also used to maintain temperature which gives energy saving efficiency.

Dry Heat

Fan Assisted Hotcupboard

Dimensions

Width - 830mm
Depth - 680mm
Height - 900mm
Weight - 45kg



Sahara Fan Model SF309

Area of hot top

672mm x 522mm

Capacity of Hot Cupboard [usable inside space]

Width - 695mm
Depth - 555mm
Usable Height Bottom shelf - 204mm
Usable Height Top Shelf - 245mm

25 covers & meals [10" plated meals stacked using plate covers]
or
95 off 10" plates stacked for heating
or
4 off 1/1GN pans side by side 150mm deep 2 on top 2 on bottom

Power Rating

1.65kw with no gantry, 1.87Kw with heated gantry.
complete with a 2m long cord set & 13amp plug
Removable Fan heating System Sahara Fan Model SF309

Materials

1.2mm 304 Grade St/ Steel Top & Supports
0.7mm 430 Grade St/ Steel Internal Structure
GN 1/1 Grid Shelves with 30mm x 30mm tube supports

Installation

All swivel castors, two braked

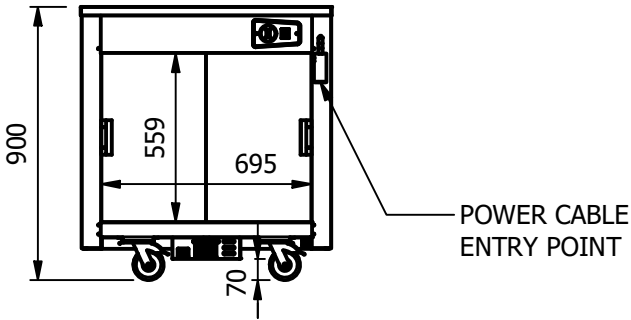
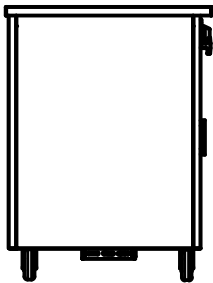
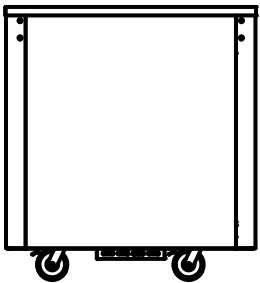
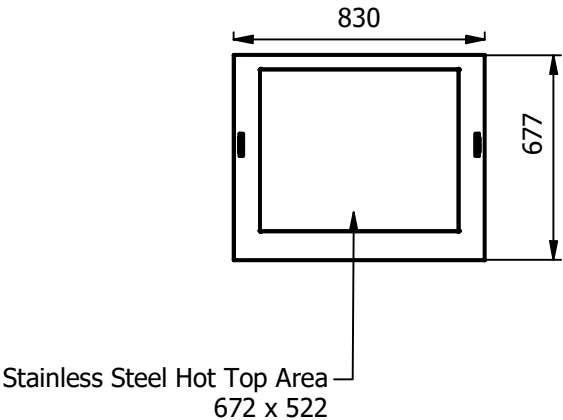

ALL SHEET METAL DIMENSIONS ARE I/S (INSIDE SIZES) (UNLESS OTHERWISE STATED)

ALL DIMENSIONS IN (mm), TOLERANCE = LINEAR ± 0.5mm, ANGULAR ± 0.5mm (OR AS STATED). ALL SHARP EDGES TO BE REMOVED FROM SHEET METAL PARTS

Product	VERSICARTE			Product No	N/A			<p>The Catering Equipment Company</p>			
Description	*** VC2HTS ***										
Material/Finish	Thickness			Desp/Date							
Legacy P/N	Weight	45kg		Quote No.			Dwg No.	VCP-072793	Issue		
Client				SO Number	STANDARD		Drawn By	ABB			
Client Project				Approved By			Date	03/07/2023			
E & R MOFFAT LTD, SEABEGS ROAD, BONNYBRIDGE, FK4 2BS, T: +44 (0)1324 812272, E: sales@ermoffat.co.uk, Web: www.ermoffat.co.uk							Scale	1 : 25	Sheet	1 / 1	A4

No reproduction or publication of this drawing may be made, and no article may be manufactured or assembled in accordance with this drawing without prior written consent. This prohibition is a term of any contract relating to this drawing. Rights reserved under the Copyright Act 1956 as amended by the Design Copyright Act 1968.