

Overview

Sanitising dispenser unit can be fixed to a rear wall. Twin touch-less automatic hand sanitiser dispenser machines with high volume, designed to pump out gel from a 0.7-litre type container with additional storage for 2 x 5 litre bottles. The fully automatic hand sanitiser dispenser is battery operated removing the requirement to touch. Simply place your hand under the dispenser and a measured dose of gel, liquid soap or sanitiser will be dispensed. The dispenser can contain liquid soap, anti-bacterial gel, or 70% alcohol hand sanitiser.



Key Features:

- Waste bin.
- Easy access lockable doors for storage.
- Adjustable for level feet and kick plate
- Practical automatic operation.
- With hygiene in mind made throughout in bright polished stainless steel.
- Designed to be topped up during usage.
- Storage for two 5 litres of antibacterial hand sanitiser.
- Bulk fill design utilising 5 litre standard bottles. No special specific cartridge types.
- Ideal for areas where soap and water are not available, the hand sanitiser dispenser offers an easy and effective hand sanitising option.





Model	Capacity	Weight (kg)	L x W x H (mm)
SDCUE	700ml	30	500 x 400 x 1489

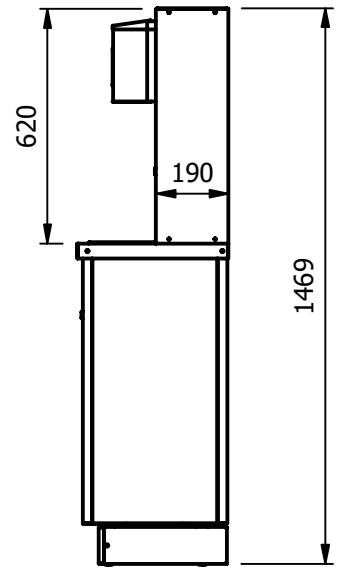
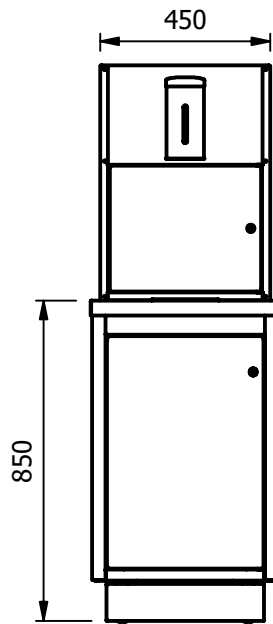
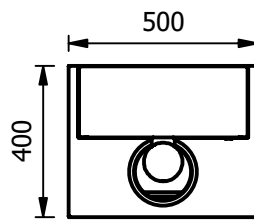

MADE IN BRITAIN

E&R Moffat Ltd.
Bonnybridge
FK4 2BS
Scotland

Find us on:



1963 - 2018

www.ermoffat.co.uk
+44 (0) 1324 812272
sales@ermoffat.co.uk