

Overview

Bainmarie with hot cupboard that has doors on both sides. E&R Moffat Ltd were the originators of a Bainmarie that could be either wet or dry heat. This type of system was designed to offer flexibility and was developed to eliminate the need to fit a low water level warning system or the expense of replacing burned out elements. Wet heat water level is an economic 20 mm deep, complete with drain valve and swing out run off tube for easy emptying /cleaning. A heavy-duty range available in four lengths designed to accommodate 1/1 Gn pans. Excellent for pre-heating plates and dishes, as well as the temporary storage of pre-cooked food. These units incorporate a very efficient heating system in addition to the fully enclosed heating elements fitted under the Bainmarie well excess residual hot air from the hot cupboard is also used to maintain temperature. Use individual or as a part of a specialised Moffat servery counter.



Key Features:

- Doors Both sides
- Insulated for increased efficiency.
- With hygiene in mind all stainless-steel construction, inner panels are bright polished.
- Forced-air, convection, heated cupboard offers unparalleled flexibility of use.
- Fan unit is easily removable for cleaning and maintenance.
- Base and door track in one piece for easy cleaning.
- Thermostatically controlled fan assisted hot cupboard. 30°-110°C.
- Thermostatically controlled bainmarie well 30°-110°C.
- Bainmarie apertures designed for gastronorm pans with raised lip all round for easy pan removal.
- Doors are very easily removed for cleaning, sliding doors have unique double life skid pads.
- Doors can be fully rotated and reinserted allowing the spare skid pads to be used offering a long and trouble-free service.
- Easy lift out GN 1/1 size multiple grid shelving, held by heavy-duty stainless-steel tube supports.
- The recessed, slide-out control panel is mounted to the operators right hand side.
- Mobile as standard, fitted with 125mm diameter castors all swivel two with brakes.
- Mobility allows for easy kitchen deep clean.
- Fully welded and sealed Bainmarie Well with drain valve and swing out drain spout
- Complete with a 2-meter-long cable and plug [most units work from a 13-amp supply

Options:

- Non-mobile on adjustable for height feet [no extra cost but must be stated on order]
- Water inlet Tap for Bainmarie fitted to worktop and piped through to under the base.
- Overhead gantry traditional pass through type. (See Moffat Kitchen pass range)
- Door Locks
- Gastronorm pans





Model	Weight (kg)	L x D x H (mm)	Height to worktop	Power Rating/ Electrical supply	Power Rating with a gantry
HB2DBS	65	947 x 700 x 910	900mm	2.4kw / 13amp	2.62kw / 13amp
HB3DBS	81	1275 x 700 x 910	900mm	2.9kw / 13amp	3.34kw / 16amp
HB4DBS	100	1603 x 700 x 910	900mm	2.9kw / 13amp	3.56kw / 16amp
HB5DBS	118	1931 x 700 x 910	900mm	3.7kw / 32amp	4.58kw / 32amp

Hot cupboard capacity:



Model	10" plated meals Stacked using plate covers	10" plates stacked for heating	Usable internal length & depth	Usable shelf height top / bottom	GN pans side by side 150mm deep
HB2DBS	25 covers / meals	95	695mm / 559mm	195mm / 210mm	4
HB3DBS	35 covers / meals	133	1023mm / 559mm	195mm / 210mm	6
HB4DBS	50 covers / meals	190	1351mm / 559mm	195mm / 210mm	8
HB5DBS	60 covers / meals	228	1679mm / 559mm	195mm / 210mm	10

Note: 10" indicates 10 inch / 255mm diameter plates

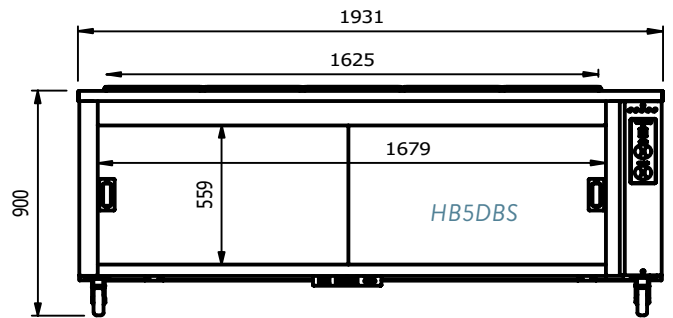
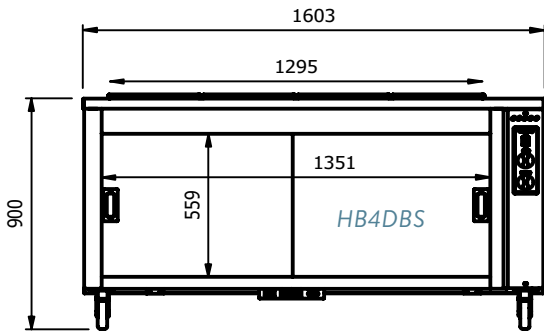
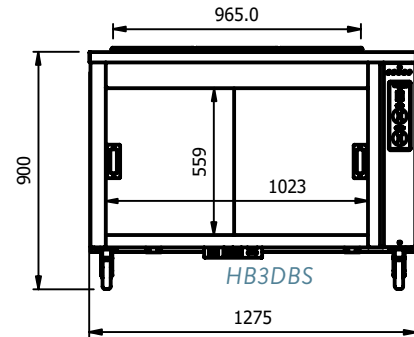
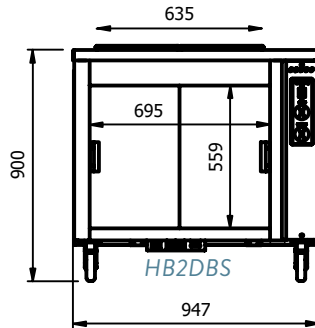
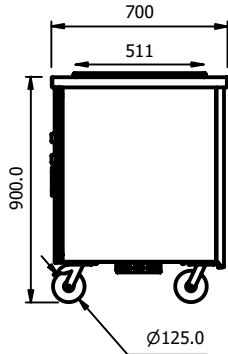

MADE IN BRITAIN

E&R Moffat Ltd.
Bonnybridge
FK4 2BS
Scotland

Find us on:



1963 - 2018

www.ermoffat.co.uk
+44 (0) 1324 812272
sales@ermoffat.co.uk