

## Overview

### FRESH HOT FOOD TO GO >>

Vertical service merchandisers, mobile and compact these units are designed to provide a self service outlet for food perfect for attractively displaying hot foods such as soup, pies, pasties, and pastries. In a customer facing environment.

Use individual where space is tight or multiple units can be lined up together to form a compact display. A mobile and flexible design, great for pop up grab and go retail stations.

Low height display shelving allows disabled access grab and go.

Multi-deck cabinet designed to look sharp and sophisticated and take up minimal space, Go-M displays make life easier. Customers select what they want simply and fast. Proper temperatures are maintained automatically and efficiently to prevent spoilage. The small foot print allows units to be positioned apart which is ideal, for social distancing.

The perfect solution for cafés, shops and garage forecourts where space and service speed is of the utmost importance, offering quick hot snacks on the go.



model: GO14

## Key Features:

- Fully fitted with high performance 50mm thick Insulation
- Efficient forced air recirculation
- Full height LED illumination
- Double glazed sides
- Superstructure made in bright polish stainless steel throughout
- Point of sale / display ticket information strips
- Mobile with all swivel castors, two with brakes
- Black glass shelf base
- Zonal digital control
- Acrylic control guard
- 24 hour operation
- Supplied with 2m long power cord and suitable plug [230v 50Hz]

## Optional extras:

- Condiment Baskets (code 139452)
- Display Tray (code 139558)
- Roller Blind for 600mm wide models (add NB to the model code)
- Roller Blind for 900mm wide models (add NB to the model code)
- Impulse Basket for mobile models (add IB to the model code)
- Sloping shelf insert (code 139488)
- Sloping shelf with two tier rack (code 142299)
- Sloping shelf with Burger slide (code 142300)
- Sloping shelf with food rack (code 142301)



model: GO13



model: GO12

**At the heart of the Go-M system is Moffat's well renowned modular convection heating cells. The Sahara fan system accurately controls recirculating warm air gently passing through each display zone.**



### Sahara fan system

Unrivalled flexibility, for over 40 years Moffat have evolved the sahara fan heating cell to become an integral part of our catalogue history. This latest development enables the ability to hold a wider variety of hot food for longer in a fresher condition.

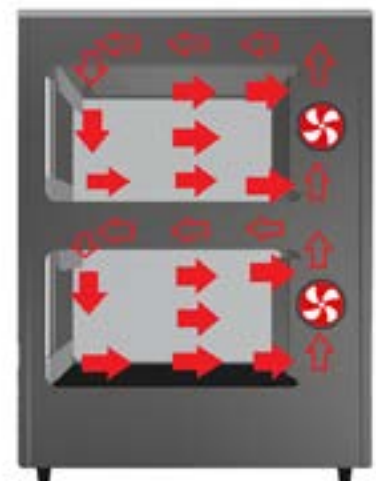

Model	No of Zones	Weight (kg)	W x D x H (mm)	Zone W x D X H (mm)	Total Capacity (m3)	Electrical Supply (single phase)	Power per Zone (kw)	Total Rating (kw)
GO12	2	69	600 x 650 x 880	539 x 445 x 252	0.12	13amp with Plug	0.75	1.50
GO13	3	109	600 x 650 x 1580	539 x 445 x 252	0.18	13amp with Plug	0.75	2.25
GO14	4	135	600 x 650 x 1858	539 x 445 x 252	0.24	13amp with Plug	0.75	3.00
GO22	2	95	900 x 650 x 880	839 x 445 x 252	0.18	13amp with Plug	1.50	3.00
GO23	3	146	900 x 650 x 1580	839 x 445 x 252	0.27	32amp with Plug	1.50	4.50
GO24	4	181	900 x 650 x 1858	839 x 445 x 252	0.36	32amp with Plug	1.50	6.00

**Energy Consumption**  
(Display set at 70C)

Model	Energy Consumption	Energy Consumption (with pull down blind)
GO12	1.02kWh / 0.51 per shelf	0.58kWh / 0.29.per shelf
GO13	1.38kWh / 0.46 per shelf	0.72kWh / 0.24 per shelf
GO14	1.80kWh / 0.45 per shelf	0.92kWh / 0.23 per shelf
GO22	2.04kWh / 1.02 per shelf	1.16kWh / 0.58 per shelf
GO23	2.76 kWh / 0.92 per shelf	1.44kWh / 0.48 per shelf
GO24	3.60 kWh / 0.90 pershelf	1.84kWh / 0.46 per shelf

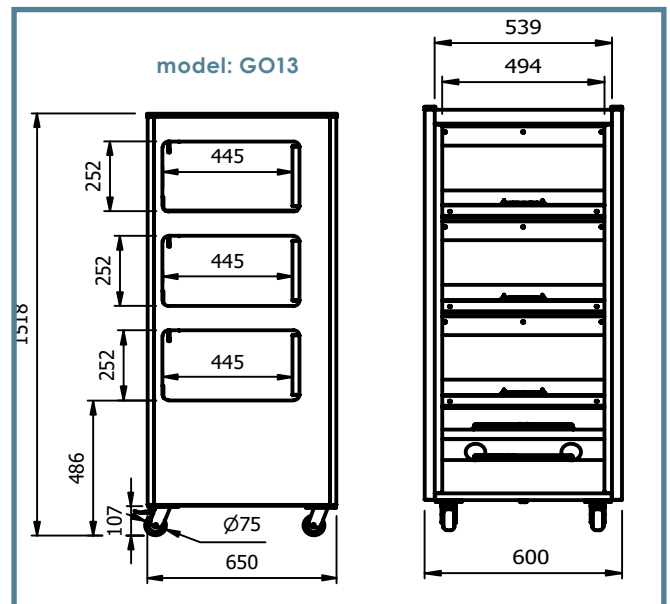
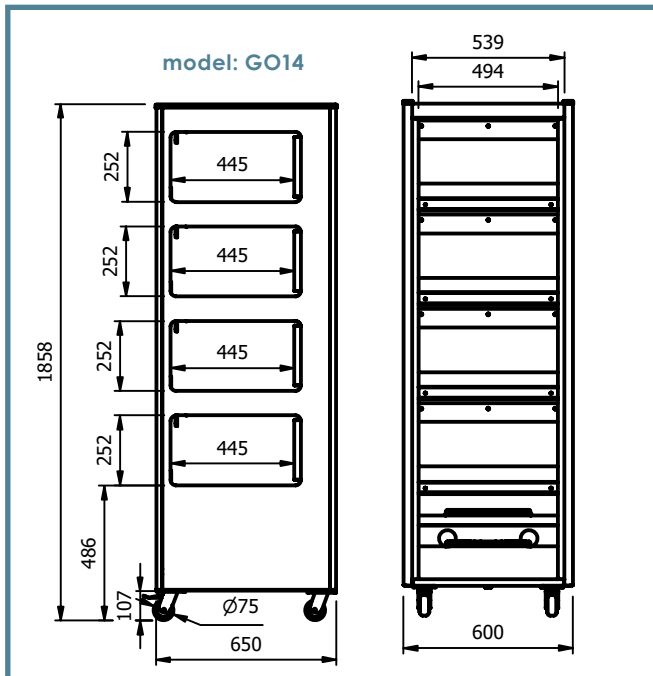
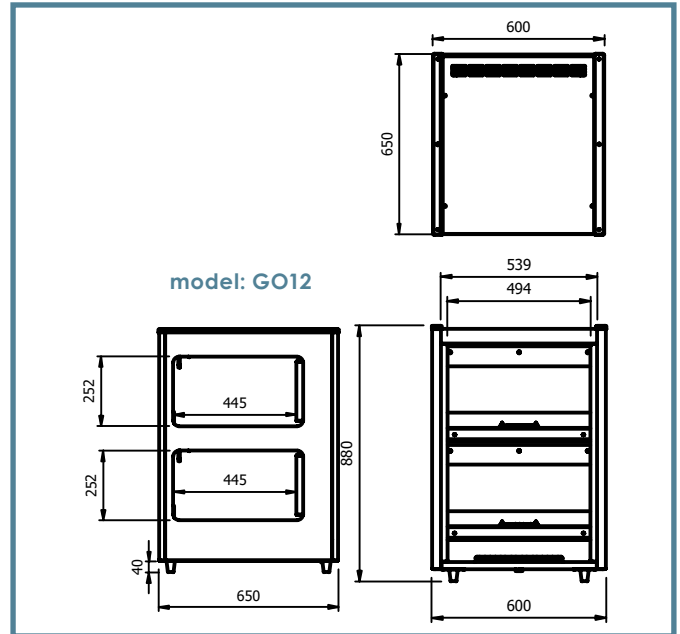

MADE IN BRITAIN

E&R Moffat Ltd.  
Bonnybridge  
FK4 2BS  
Scotland

Find us on:



www.ermoffat.co.uk  
+44 (0) 1324 812272  
sales@ermoffat.co.uk