

A (1 : 3)

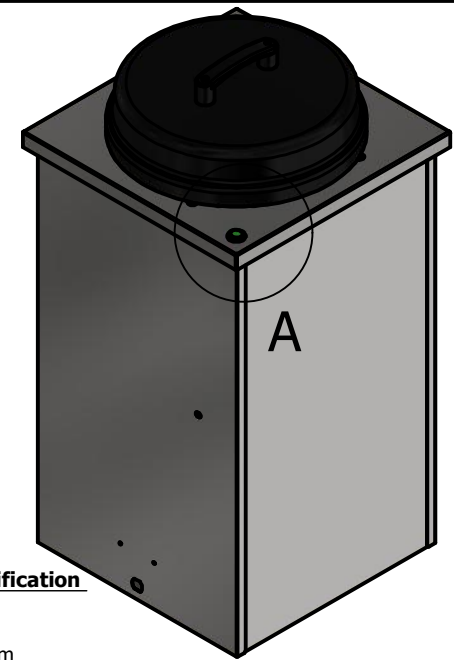

Adjustable Guide Rods to suit 8" - 12" [203mm - 305 mm] Plates

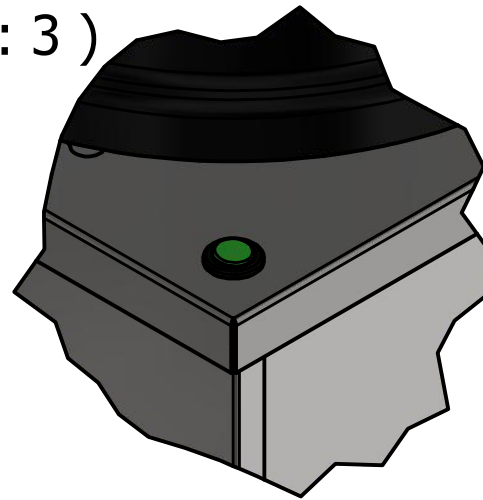
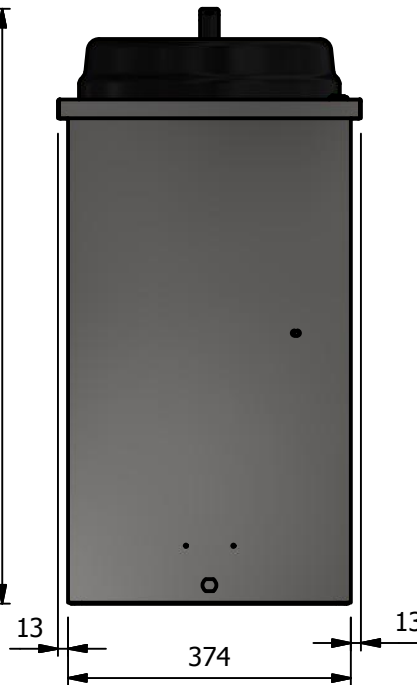
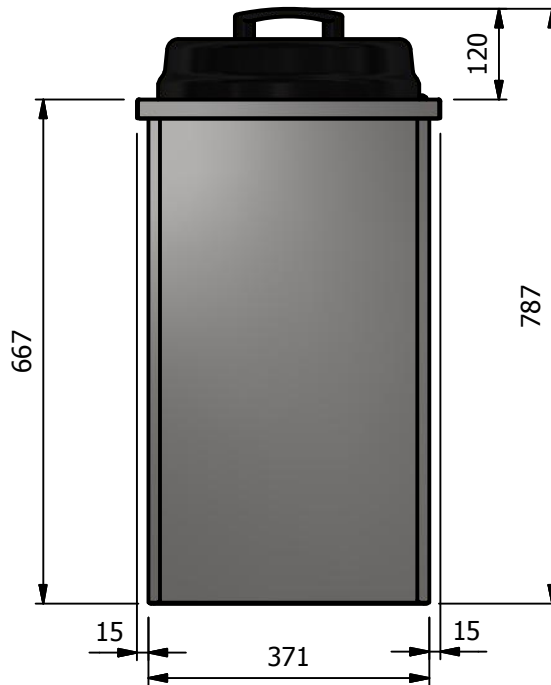
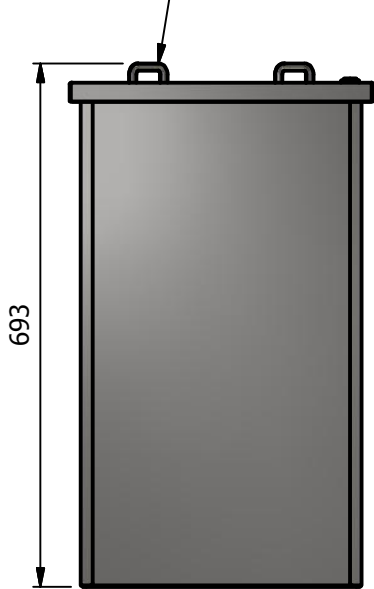

Moffat Specification

Dimensions

Width - 400mm
Depth - 400mm
Height - 788mm
Weight - 16kg

Power Rating

0.6 kw
complete with a 2m long cord set & 13amp plug

Materials

0.7mm 430 Grade St/Steel Gantry Hood
1.2mm 304 Grade St/ Steel Top & Supports
1.2mm 430 Grade St Steel Ancillary Parts
Plate Cover Black ABS plastic

Capacity

65 plates depending on type and thickness

Installation

Counter Top Flush Fit Cut Out Dimensions
406mm x 406mm x 25mm
Counter Support Cut Out Dimensions
376mm x 376mm

ALL SHEET METAL DIMENSIONS ARE I/S (INSIDE SIZES) (UNLESS OTHERWISE STATED)

ALL DIMENSIONS IN (mm), TOLERANCE = LINEAR ± 0.5mm, ANGULAR ± 0.5mm (OR AS STATED). ALL SHARP EDGES TO BE REMOVED FROM SHEET METAL PARTS

Product	DROP-IN RANGE			Product No	 The Catering Equipment Company			
Description	DHP1							
Material/Finish	Thickness		Desp/Date		<small>No reproduction or publication of this drawing may be made, and no article may be manufactured or assembled in accordance with this drawing without prior written consent. This prohibition is a term of any contract relating to this drawing. Rights reserved under the Copyright Act 1956 as amended by the Design Copyright Act 1968.</small>			
Legacy P/N	Weight	16kg	Quote No.					
Client			SO Number	N/A	Dwg No.	DIP-032095	Issue	
Client Project			Approved By		Drawn By	nraymen		
E & R MOFFAT LTD, SEABEGS ROAD, BONNYBRIDGE, FK4 2BS, T: +44 (0)1324 812272, E: sales@ermoffat.co.uk, Web: www.ermoffat.co.uk					Date	08/04/2019		
					Scale	1 : 10	Sheet	1 / 1
								A4