

**Moffat Specification**

Dimensions

Width - 1814mm  
 Depth - 660mm  
 Height - 603mm  
 Weight - 68kg

Power Rating

1.780 kw  
 complete with a 2m long cord set & 13amp plug

Materials

0.7mm 430 Grade St/Steel Gantry Hood  
 1.2mm 304 Grade St/ Steel Top & Supports  
 1.2mm 430 Grade St Steel Ancillary Parts  
 1.2mm Galvanised Steel Inner Supports  
 6mm Tempered Glass  
 Neo-Ceram Hot Plates  
 Quartz Lamps

Installation

Counter Top Flush Fit Cut Out Dimensions  
 1820mm x 666mm x 25mm  
 Counter Support Cut Out Dimensions  
 1796mm x 642mm

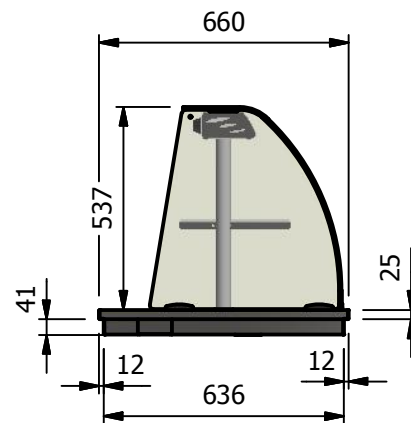
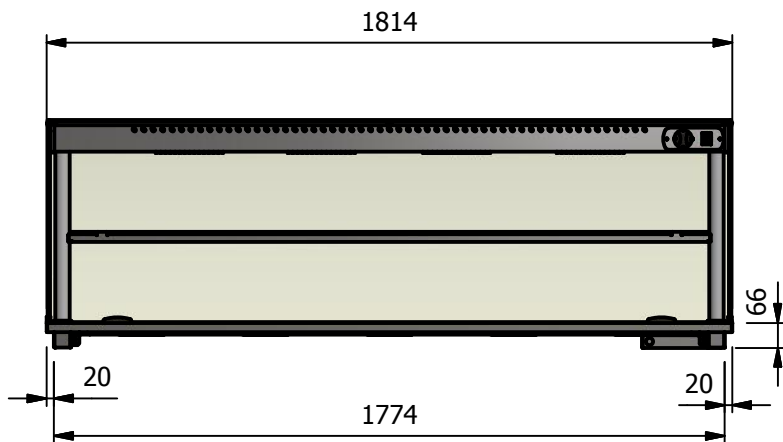

ALL SHEET METAL DIMENSIONS ARE I/S (INSIDE SIZES) (UNLESS OTHERWISE STATED)

ALL DIMENSIONS IN (mm), TOLERANCE = LINEAR ± 0.5mm, ANGULAR ± 0.5mm (OR AS STATED). ALL SHARP EDGES TO BE REMOVED FROM SHEET METAL PARTS

Product	DROP-IN RANGE			Product No			
Description	D5HTD						
Material/Finish	Thickness			Desp/Date			
Legacy P/N	Weight	68kg		Quote No.			
Client				SO Number	N/A		
Client Project				Approved By			
				<small>© No reproduction or publication of this drawing may be made, and no article may be manufactured or assembled in accordance with this drawing without prior written consent. This prohibition is a term of any contract relating to this drawing. Rights reserved under the Copyright Act 1956 as amended by the Design Copyright Act 1968.</small>			
		Dwg No.	DIP-022861		Issue		
		Drawn By	ABB		-		
		Date	15/01/2019				
E & R MOFFAT LTD, SEABEGS ROAD, BONNYBRIDGE, FK4 2BS, T: +44 (0)1324 812272, E: sales@ermoffat.co.uk, Web: www.ermoffat.co.uk		Scale	1:20		Sheet	1 / 2	<b>A4</b>