

**Important Design Parameters**

On the operators side of the Servery Counter a removable service panel is required to allow access to service heating elements etc. The dimensions of the access aperture must be no less than 1653mm x 145mm.

Additionally access is required to manually operate the drain valve. Drain connection is via 15mm lever ball valve.

**Warning**

The unit must be manually filled with water. Capacity 33 litre  
A depth of 40mm must be maintained during operation.  
[water level marker fitted to element cover]

**Moffat Specification**

**Wet Heat**  
Immersion heated Bainmarie Well

**Dimensions**  
Width - 1814mm  
Depth - 660mm  
Height - 649mm  
Weight - 89kg

**Power Rating**  
5.88kw  
complete with a 2m long cord set & 32amp plug

**Materials**  
1.2mm 304 Grade St/ Steel Top, Supports & Well  
0.7mm 430 Grade St/ Steel External Structure  
0.7mm Galvanised Steel Undercarrage  
6mm Tempered Glass  
Quartz Lamps

**Installation**  
Counter Top Flush Fit Cut Out Dimensions  
1820mm x 666mm x 25mm  
Counter Support Cut Out Dimensions  
1796mm x 642mm

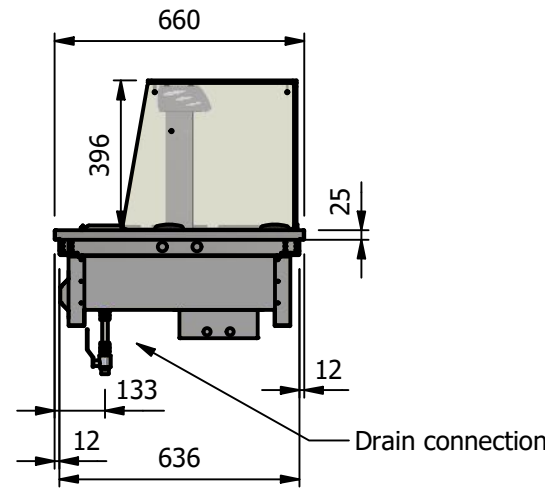
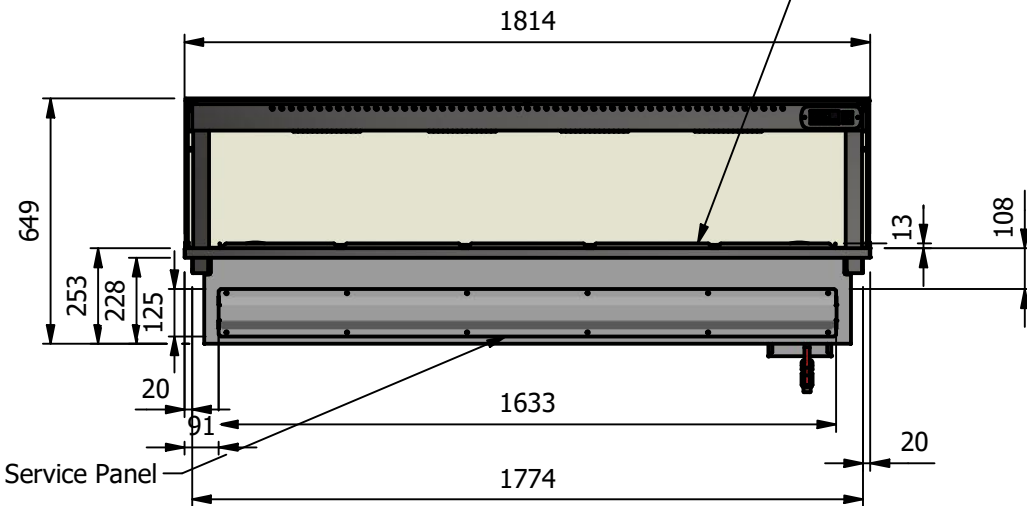

ALL SHEET METAL DIMENSIONS ARE I/S (INSIDE SIZES) (UNLESS OTHERWISE STATED)

ALL DIMENSIONS IN (mm), TOLERANCE = LINEAR ± 0.5mm, ANGULAR ± 0.5mm (OR AS STATED). ALL SHARP EDGES TO BE REMOVED FROM SHEET METAL PARTS

|   |               |      |             |            |   |            |       |           |
|---|---------------|------|-------------|------------|---|------------|-------|-----------|
| Product   | DROP-IN RANGE |      |             | Product No | <br>The Catering Equipment Company   |            |       |           |
| Description   | D5BMWSLF      |      |             |            |   |            |       |           |
| Material/Finish   | Thickness     |      | Desp/Date   |            | No reproduction or publication of this drawing may be made, and no article may be manufactured or assembled in accordance with this drawing without prior written consent. This prohibition is a term of any contract relating to this drawing. Rights reserved under the Copyright Act 1956 as amended by the Design Copyright Act 1968. |            |       |           |
| Legacy P/N  | Weight        | 89kg | Quote No.   |            |   |            |       |           |
| Client  |               |      | SO Number   | N/A        | Dwg No.   | DIP-022849 | Issue |           |
| Client Project  |               |      | Approved By |            | Drawn By  | ABB        |       |           |
| E & R MOFFAT LTD, SEABEGS ROAD, BONNYBRIDGE, FK4 2BS, T: +44 (0)1324 812272, E: sales@ermoffat.co.uk, Web: www.ermoffat.co.uk |               |      |             |            | Date  | 16/01/2019 |       |           |
|   |               |      |             |            | Scale   | 1:20       | Sheet | 1 / 2     |
|   |               |      |             |            |   |            |       | <b>A4</b> |