

A ( 1 : 10 )

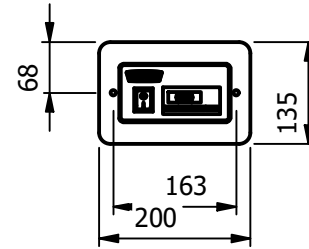

**Moffat Specification**

Dry Heat  
Fan Assisted Bainmarie Well

Dimensions  
Width - 1814mm  
Depth - 660mm  
Height - 66mm  
Weight - 44kg

Power Rating  
1.900 kw  
complete with a 2m long cord set & 13amp plug  
Removable Fan heating System Sahara Fan Model SF319

Materials  
1.2mm 304 Grade St/ Steel Top & Supports  
0.7mm 430 Grade St/ Steel Internal Structure  
0.7mm Galvanised Steel Undercarrage

Installation  
Counter Top Flush Fit Cut Out Dimensions  
1820mm x 666mm x 25mm  
Counter Support Cut Out Dimensions  
1796mm x 642mm

Control Box  
Panel Mounted Cut Out Dimension  
185mm x 120mm  
2m Long Power Cable Connecting  
Control Box to Base unit

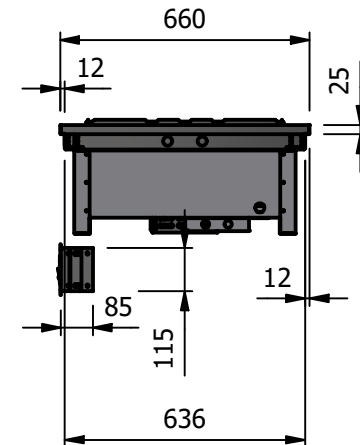
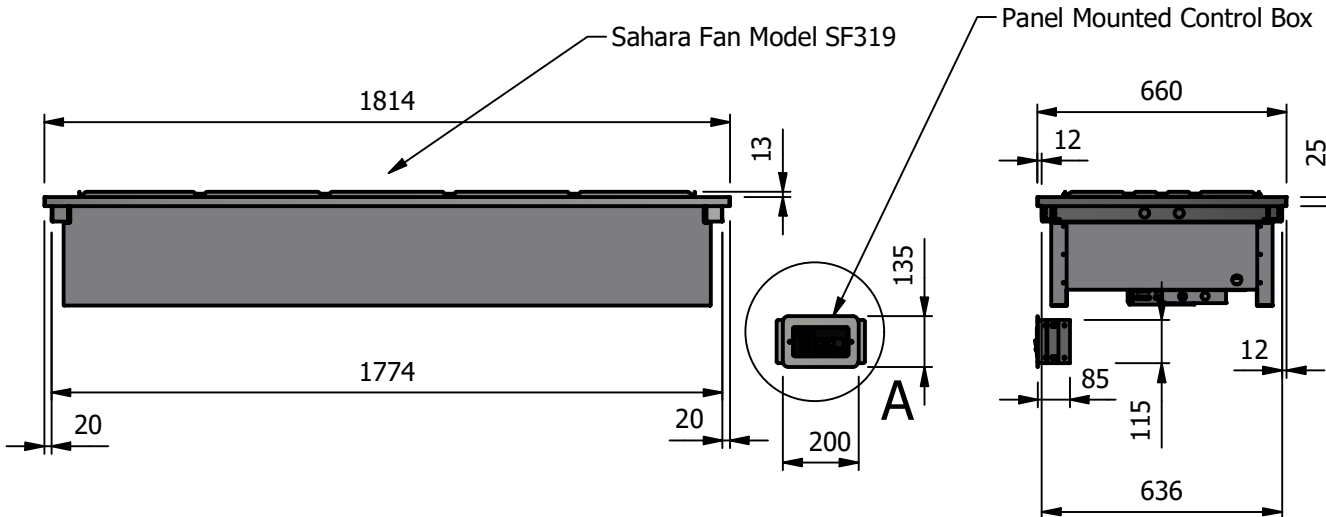

ALL SHEET METAL DIMENSIONS ARE I/S (INSIDE SIZES) (UNLESS OTHERWISE STATED)

ALL DIMENSIONS IN (mm), TOLERANCE = LINEAR ± 0.5mm, ANGULAR ± 0.5mm (OR AS STATED). ALL SHARP EDGES TO BE REMOVED FROM SHEET METAL PARTS

|   |               |      |  |             |            |       |            |
|---|---------------|------|--|-------------|------------|-------|------------|
| Product   | DROP-IN RANGE |      |  | Product No  |            |       |            |
| Description   | D5BMNG        |      |  |             |            |       |            |
| Material/Finish   | Thickness     |      |  | Desp/Date   |            |       |            |
| Legacy P/N  | Weight        | 44kg |  | Quote No.   |            |       |            |
| Client  |               |      |  | SO Number   | N/A        |       |            |
| Client Project  |               |      |  | Approved By |            |       |            |
|   |               |      |  | Dwg No.     | DIP-016610 |       | Issue      |
|   |               |      |  | Drawn By    | ABB        |       | -          |
|   |               |      |  | Date        | 15/01/2019 |       |            |
| E & R MOFFAT LTD, SEABEGS ROAD, BONNYBRIDGE, FK4 2BS, T: +44 (0)1324 812272, E: sales@ermoffat.co.uk, Web: www.ermoffat.co.uk |               |      |  | Scale       | 1:20       | Sheet | 1 / 2   A4 |

No reproduction or publication of this drawing may be made, and no article may be manufactured or assembled in accordance with this drawing without prior written consent. This prohibition is a term of any contract relating to this drawing. Rights reserved under the Copyright Act 1956 as amended by the Design Copyright Act 1968.

