

Moffat Specification

Dimensions

Width - 1486mm
 Depth - 660mm
 Height - 462mm
 Weight - 59kg

Power Rating

1.380 kw
 complete with a 2m long cord set & 13amp plug

Materials

0.7mm 430 Grade St/Steel Gantry Hood
 1.2mm 304 Grade St/ Steel Top & Supports
 1.2mm 430 Grade St Steel Ancillary Parts
 1.2mm Galvanised Steel Inner Supports
 6mm Tempered Glass
 Neo-Ceram Hot Plates
 Quartz Lamps

Installation

Counter Top Flush Fit Cut Out Dimensions
 1492mm x 666mm x 25mm
 Counter Support Cut Out Dimensions
 1468mm x 642mm

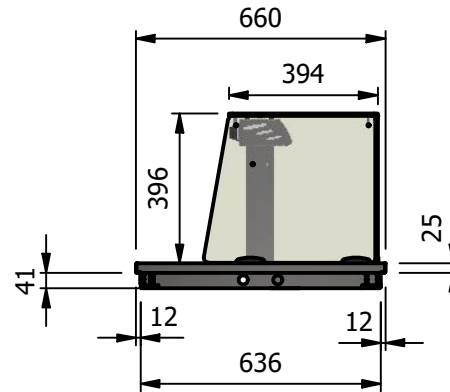
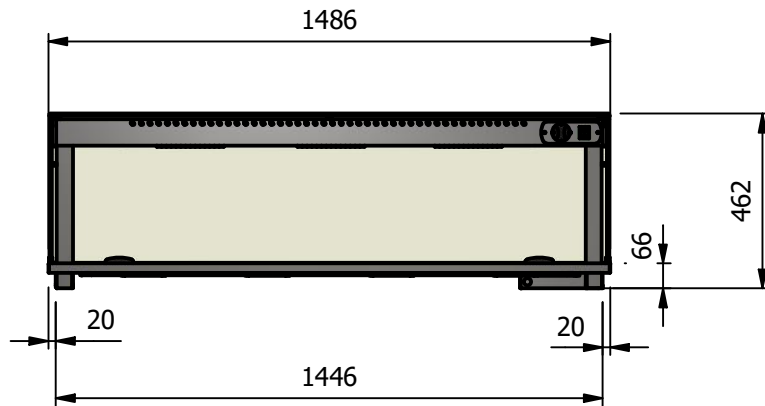

ALL SHEET METAL DIMENSIONS ARE I/S (INSIDE SIZES) (UNLESS OTHERWISE STATED)

ALL DIMENSIONS IN (mm), TOLERANCE = LINEAR ± 0.5mm, ANGULAR ± 0.5mm (OR AS STATED). ALL SHARP EDGES TO BE REMOVED FROM SHEET METAL PARTS

| | | | | | | | | | | |
|---|---------------|------|--|-------------|-----|---|---|-------|-------|-----------|
| Product | DROP-IN RANGE | | | Product No | |  The Catering Equipment Company | No reproduction or publication of this drawing may be made, and no article may be manufactured or assembled in accordance with this drawing without prior written consent. This prohibition is a term of any contract relating to this drawing. Rights reserved under the Copyright Act 1956 as amended by the Design Copyright Act 1968. | | | |
| Description | D4HTSLF | | | Desp/Date | | | | | | |
| Material/Finish | Thickness | | | Quote No. | | | | | | |
| Legacy P/N | Weight | 59kg | | SO Number | N/A | Dwg No. | DIP-020634 | Issue | | |
| Client | | | | Approved By | | Drawn By | ABB | | | |
| Client Project | | | | | | Date | 15/01/2019 | | | |
| E & R MOFFAT LTD, SEABEGS ROAD, BONNYBRIDGE, FK4 2BS, T: +44 (0)1324 812272, E: sales@ermoffat.co.uk, Web: www.ermoffat.co.uk | | | | | | Scale | 1 : 20 | Sheet | 1 / 2 | A4 |