

**Moffat Specification**

Dimensions

Width - 1486mm  
 Depth - 660mm  
 Height - 480mm  
 Weight - 57kg

Power Rating

1.680 kw  
 complete with a 2m long cord set & 13amp plug

Materials

0.7mm 430 Grade St/Steel Gantry Hood  
 1.2mm 304 Grade St/ Steel Top & Supports  
 1.2mm 430 Grade St Steel Ancillary Parts  
 1.2mm Galvanised Steel Inner Supports  
 6mm Tempered Glass  
 Neo-Ceram Hot Plates  
 Quartz Lamps

Installation

Counter Top Flush Fit Cut Out Dimensions  
 1492mm x 666mm x 25mm  
 Counter Support Cut Out Dimensions  
 1468mm x 642mm

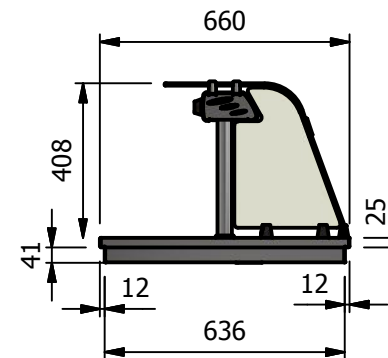
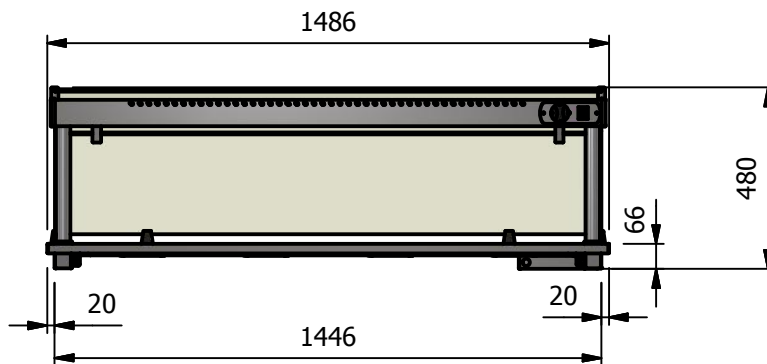

ALL SHEET METAL DIMENSIONS ARE I/S (INSIDE SIZES) (UNLESS OTHERWISE STATED)

ALL DIMENSIONS IN (mm), TOLERANCE = LINEAR ± 0.5mm, ANGULAR ± 0.5mm (OR AS STATED). ALL SHARP EDGES TO BE REMOVED FROM SHEET METAL PARTS

Product	DROP-IN RANGE			Product No		 The Catering Equipment Company	No reproduction or publication of this drawing may be made, and no article may be manufactured or assembled in accordance with this drawing without prior written consent. This prohibition is a term of any contract relating to this drawing. Rights reserved under the Copyright Act 1956 as amended by the Design Copyright Act 1968.			
Description	D4HTF			Desp/Date						
Material/Finish	Thickness			Quote No.						
Legacy P/N	Weight	57kg		SO Number	N/A	Dwg No.	DIP-020632	Issue		
Client				Approved By		Drawn By	ABB			
Client Project						Date	15/01/2019			
E & R MOFFAT LTD, SEABEGS ROAD, BONNYBRIDGE, FK4 2BS, T: +44 (0)1324 812272, E: sales@ermoffat.co.uk, Web: www.ermoffat.co.uk						Scale	1:20	Sheet	1 / 2	<b>A4</b>