

**Important Design Parameters**

On the operators side of the Servery Counter a removable service panel is required to allow access to service heating elements etc. The dimensions of the access aperture must be no less than 1325mm x 145mm.

Additionally access is required to manually operate the drain valve. Drain connection is via 15mm lever ball valve.

**Warning**

The unit must be manually filled with water. Capacity 27 litre  
A depth of 40mm must be maintained during operation.  
[water level marker fitted to element cover]

**Moffat Specification**

**Wet Heat**  
Immersion heated Bainmarie Well

**Dimensions**  
Width - 1486mm  
Depth - 660mm  
Height - 649mm  
Weight - 75kg

**Power Rating**  
4.66kw  
complete with a 2m long cord set & 32amp plug

**Materials**  
1.2mm 304 Grade St/ Steel Top, Supports & Well  
0.7mm 430 Grade St/ Steel External Structure  
0.7mm Galvanised Steel Undercarrage  
6mm Tempered Glass  
Quartz Lamps

**Installation**  
Counter Top Flush Fit Cut Out Dimensions  
1492mm x 666mm x 25mm  
Counter Support Cut Out Dimensions  
1468mm x 642mm

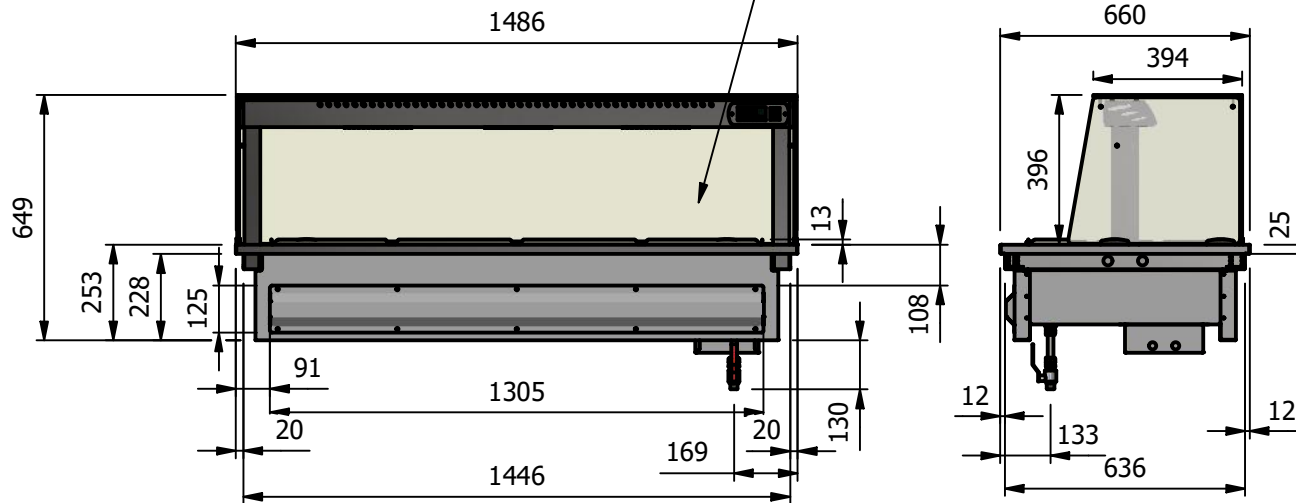

ALL SHEET METAL DIMENSIONS ARE 1/8 (INSIDE SIZES) (UNLESS OTHERWISE STATED)

ALL DIMENSIONS IN (mm), TOLERANCE = LINEAR ± 0.5mm, ANGULAR ± 0.5mm (OR AS STATED). ALL SHARP EDGES TO BE REMOVED FROM SHEET METAL PARTS

Product	DROP-IN RANGE			Product No			
Description	D4BMWSLF			<small>No reproduction or publication of this drawing may be made, and no article may be manufactured or assembled in accordance with this drawing without prior written consent. This prohibition is a term of any contract relating to this drawing. Rights reserved under the Copyright Act 1956 as amended by the Design Copyright Act 1968.</small>			
Material/Finish	Thickness			Desp/Date			
Legacy P/N	Weight	75kg		Quote No.			
Client				SO Number	N/A		
Client Project				Approved By			
				Dwg No.	DIP-022848		Issue
				Drawn By	ABB		-
				Date	16/01/2019		
E & R MOFFAT LTD, SEABEGS ROAD, BONNYBRIDGE, FK4 2BS, T: +44 (0)1324 812272, E: sales@ermoffat.co.uk, Web: www.ermoffat.co.uk				Scale	1:20		Sheet 1 / 2
							<b>A4</b>

