

Sahara Fan Model SF315

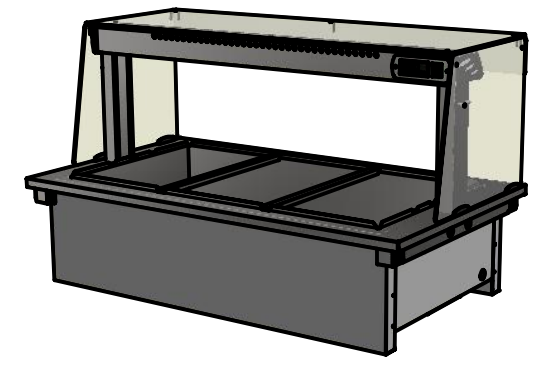

Moffat Specification

- Dry Heat
Fan Assisted Bainmarie Well

- Dimensions
Width - 1158mm
Depth - 660mm
Height - 684mm
Weight - 47kg

- Power Rating
1.940kw
complete with a 2m long cord set & 13amp plug
Removable Fan heating System Sahara Fan Model SF315

- Materials
1.2mm 304 Grade St/ Steel Top & Supports
0.7mm 430 Grade St/ Steel Internal Structure
0.7mm Galvanised Steel Undercarrage
6mm Tempered Glass
Quartz Lamps

- Installation
Counter Top Flush Fit Cut Out Dimensions
1164mm x 666mm x 25mm
Counter Support Cut Out Dimensions
1140mm x 642mm

ALL SHEET METAL DIMENSIONS ARE I/S (INSIDE SIZES) (UNLESS OTHERWISE STATED) ALL DIMENSIONS IN (mm), TOLERANCE = LINEAR ± 0.5mm, ANGULAR ± 0.5mm (OR AS STATED). ALL SHARP EDGES TO BE REMOVED FROM SHEET METAL PARTS

Product	DROP-IN RANGE			Product No		<small>No reproduction or publication of this drawing may be made, and no article may be manufactured or assembled in accordance with this drawing without prior written consent. This prohibition is a term of any contract relating to this drawing. Rights reserved under the Copyright Act 1956 as amended by the Design Copyright Act 1968.</small>	 The Catering Equipment Company		
Description	D3BMSL								
Material/Finish	Thickness		Desp/Date			Dwg No.	DIP-020877	Issue	
Legacy P/N	Weight	47kg	Quote No.			Drawn By	ABB	-	
Client			SO Number	N/A		Date	15/01/2019		
Client Project			Approved By			Scale	1:20	Sheet	
E & R MOFFAT LTD, SEABEGS ROAD, BONNYBRIDGE, FK4 2BS, T: +44 (0)1324 812272, E: sales@ermoffat.co.uk, Web: www.ermoffat.co.uk								1 / 2	A4