

Moffat Specification

Dry Heat
Fan Assisted Bainmarie Well

Dimensions
Width - 1158mm
Depth - 660mm
Height - 66mm
Weight - 29kg

Power Rating
1.5 kw
complete with a 2m long cord set & 13amp plug
Removable Fan heating System Sahara Fan Model SF315

Materials
1.2mm 304 Grade St/ Steel Top & Supports
0.7mm 430 Grade St/ Steel Internal Structure
0.7mm Galvanised Steel Undercarrage

Installation
Counter Top Flush Fit Cut Out Dimensions
1164mm x 666mm x 25mm
Counter Support Cut Out Dimensions
1140mm x 642mm

Control Box
Panel Mounted Cut Out Dimension
185mm x 120mm
2m Long Power Cable Connecting
Control Box to Base unit

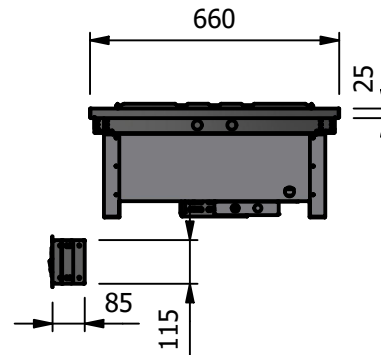
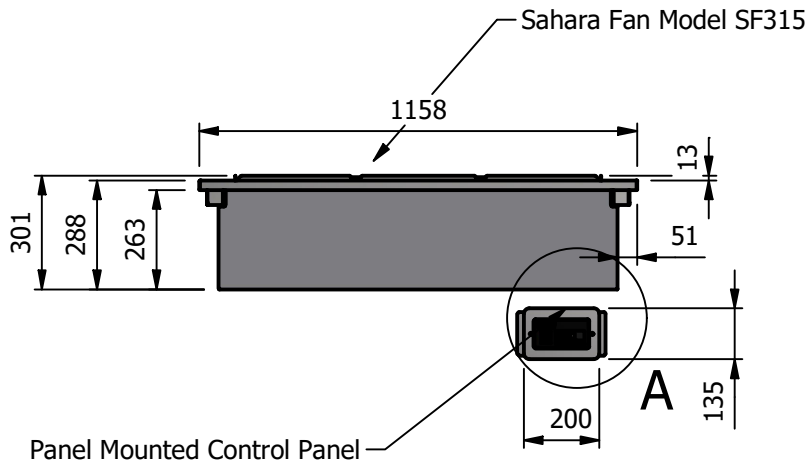

ALL SHEET METAL DIMENSIONS ARE I/S (INSIDE SIZES) (UNLESS OTHERWISE STATED)

ALL DIMENSIONS IN (mm), TOLERANCE = LINEAR ± 0.5mm, ANGULAR ± 0.5mm (OR AS STATED). ALL SHARP EDGES TO BE REMOVED FROM SHEET METAL PARTS

Product	DROP-IN RANGE			Product No		 The Catering Equipment Company				
Description	D3BMMNG									
Material/Finish	Thickness			Desp/Date		No reproduction or publication of this drawing may be made, and no article may be manufactured or assembled in accordance with this drawing without prior written consent. This prohibition is a term of any contract relating to this drawing. Rights reserved under the Copyright Act 1956 as amended by the Design Copyright Act 1968.	 The Catering Equipment Company			
Legacy P/N	Weight	29kg		Quote No.				Dwg No.	DIP-016607	Issue
Client				SO Number	N/A	Drawn By	ABB	-		
Client Project				Approved By		Date	15/01/2019			
E & R MOFFAT LTD, SEABEGS ROAD, BONNYBRIDGE, FK4 2BS, T: +44 (0)1324 812272, E: sales@ermoffat.co.uk, Web: www.ermoffat.co.uk						Scale	1:20	Sheet	1 / 2	A4