

<< AirFlow

**Important Design Parameters**

Allowances must be made for air venting.  
 The under slung compressor must have an unrestricted air flow.  
 Proper venting must be provided ensuring cool air from the room can be drawn in through the condensing coil and out the other side.  
 The 'Plenum Duct' supplied should be fitted between the unit & the shop-fitted counter panels.

**Warning**

Do not install unit in draughty conditions where the air movement is greater than 0.2mtr/sec.  
 e.g. near entrance/exit doors, open windows, under air conditioning units or a ceiling mounted fan  
 Do not install units where there is high radiated heat, e.g. direct sunlight, room heaters, or bright spot lights.  
 Ambient room conditions must not exceed 25°C or a relative humidity of 60%.  
 Blocked vents will cause reduced refrigeration efficiency and lead to malfunction

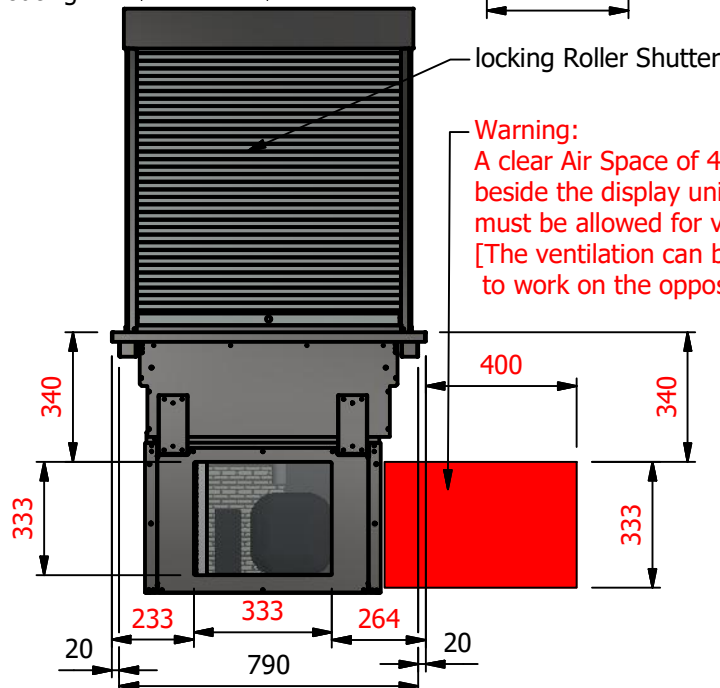
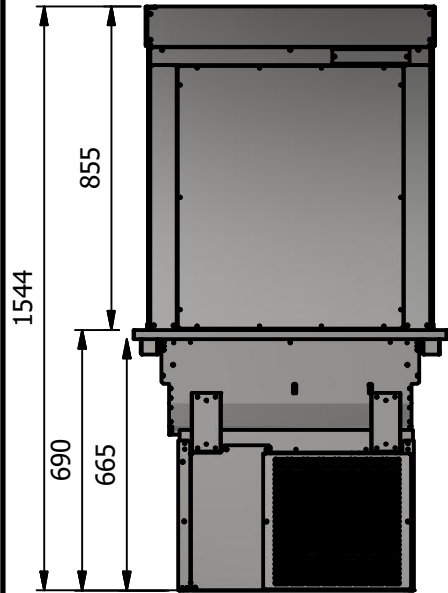
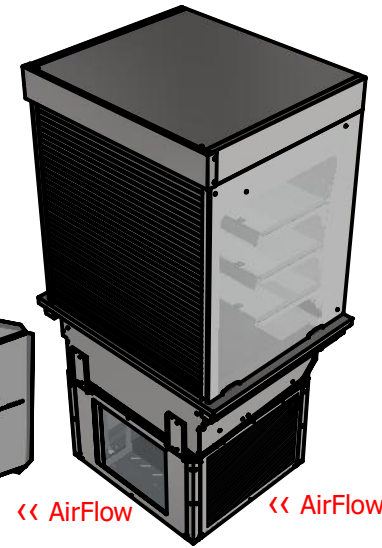
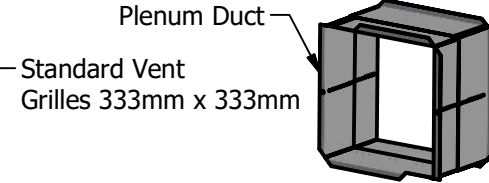
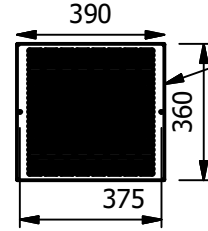
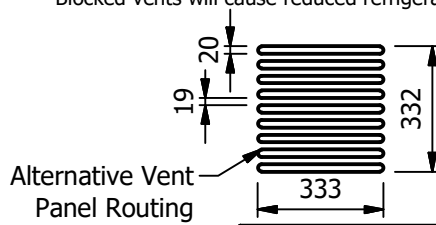
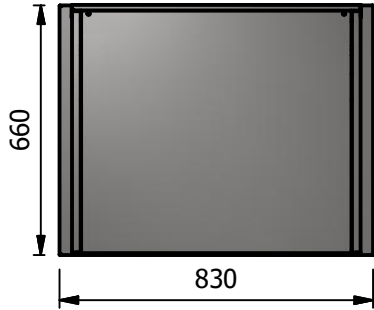

**Warning:**  
 A clear Air Space of 400mm beside the display unit must be allowed for ventilation.  
 [The ventilation can be configured to work on the opposite side]

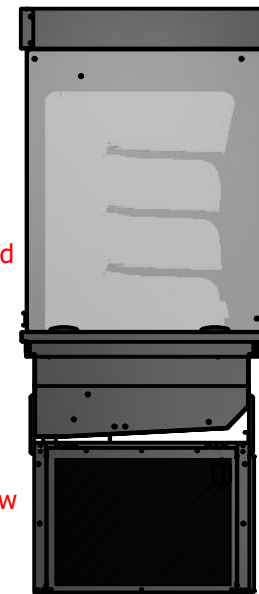

**Moffat Specification**

**Dimensions**  
 Width - 830mm  
 Depth - 660mm  
 Height - 1545mm  
 Weight - 130kg  
 Well - 656mm x 505mm x 100mm  
 Shelves - 724mm x 285mm

**Power Rating**  
 1.5 kw  
 complete with a 2m long cord set & 13amp plug

**Materials**  
 0.7mm 430 Grade St/Steel Gantry Hood  
 1.2mm 304 Grade St/ Steel Top & Supports  
 1.2mm 430 Grade St Steel Ancillary Parts  
 1.2mm Galvanised Steel Inner Supports  
 6mm Tempered Glass  
 LED Illumination

**Installation**  
 Counter Top Flush Fit Cut Out Dimensions  
 836mm x 666mm x 25mm  
 Counter Support Cut Out Dimensions  
 812mm x 642mm

ALL SHEET METAL DIMENSIONS ARE I/S (INSIDE SIZES) (UNLESS OTHERWISE STATED)

ALL DIMENSIONS IN (mm), TOLERANCE = LINEAR ± 0.5mm, ANGULAR ± 0.5mm (OR AS STATED). ALL SHARP EDGES TO BE REMOVED FROM SHEET METAL PARTS

Product	DROP-IN RANGE			Product No	 The Catering Equipment Company				
Description	D2RDSAFC								
Material/Finish	Thickness		Desp/Date		No reproduction or publication of this drawing may be made, and no article may be manufactured or assembled in accordance with this drawing without prior written consent. This prohibition is a term of any contract relating to this drawing. Rights reserved under the Copyright Act 1956 as amended by the Design Copyright Act 1968.				
Legacy P/N	Weight	130kg	Quote No.						
Client			SO Number	N/A	Dwg No.	DIP-058494	Issue		
Client Project			Approved By		Drawn By	ABB	-		
E & R MOFFAT LTD, SEABEGS ROAD, BONNYBRIDGE, FK4 2BS, T: +44 (0)1324 812272, E: sales@ermoffat.co.uk, Web: www.ermoffat.co.uk					Date	15/01/2019			
					Scale	1:20	Sheet	1 / 1	<b>A4</b>