

Important Design Parameters

Allowances must be made for air venting.
 The under slung compressor must have an unrestricted air flow.
 Proper venting must be provided ensuring cool air from the room can be drawn in through the condensing coil and out the other side.
 The 'Plenum Duct' supplied should be fitted between the unit & the shop-fitted counter panels.

Warning

Do not install unit in draughty conditions where the air movement is greater than 0.2mtr/sec.
 e.g. near entrance/exit doors, open windows, under air conditioning units or a ceiling mounted fan
 Do not install units where there is high radiated heat, e.g. direct sunlight, room heaters, or bright spot lights.
 Ambient room conditions must not exceed 25°C or a relative humidity of 60%.
 Blocked vents will cause reduced refrigeration efficiency and lead to malfunction

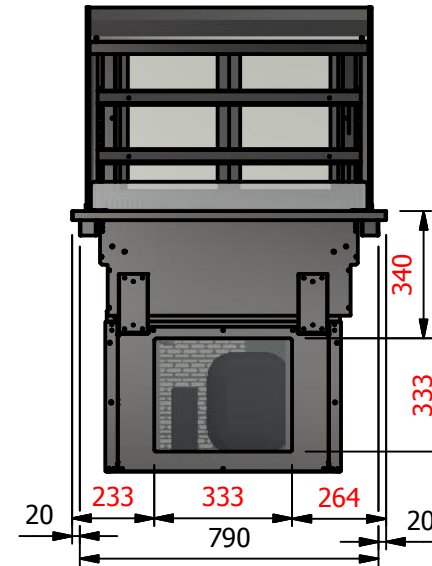
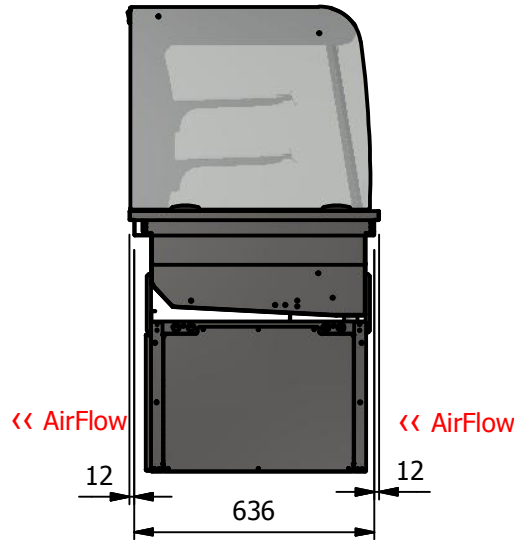
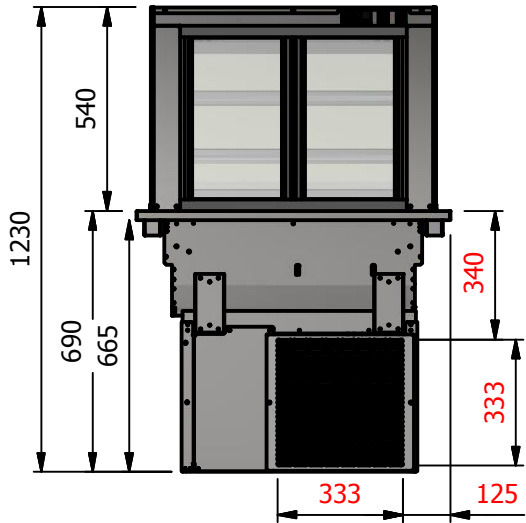
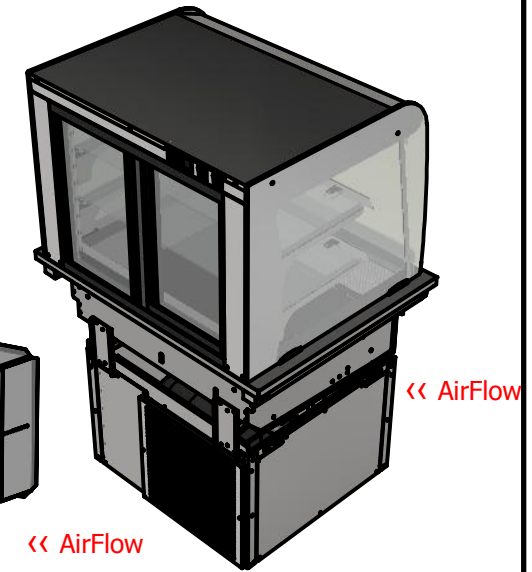
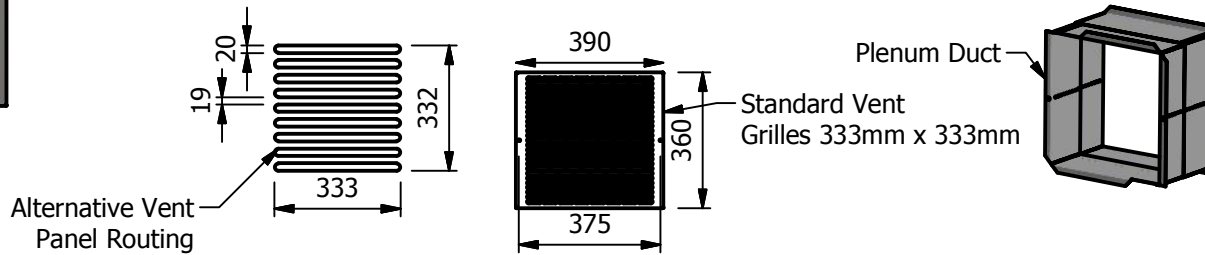

Moffat Specification

- Dimensions**
 Width - 830mm
 Depth - 660mm
 Height - 1230mm
 Weight - 112kg
 Well - 656mm x 505mm x 100mm
 Shelves - 724mm x 285mm
- Power Rating**
 1.5 kw
 complete with a 2m long cord set & 13amp plug
- Materials**
 0.7mm 430 Grade St/Steel Gantry Hood
 1.2mm 304 Grade St/ Steel Top & Supports
 1.2mm 430 Grade St Steel Ancillary Parts
 1.2mm Galvanised Steel Inner Supports
 6mm Tempered Glass
 LED Illumination
- Installation**
 Counter Top Flush Fit Cut Out Dimensions
 836mm x 666mm x 25mm
 Counter Support Cut Out Dimensions
 812mm x 642mm

ALL SHEET METAL DIMENSIONS ARE I/S (INSIDE SIZES) (UNLESS OTHERWISE STATED)

ALL DIMENSIONS IN (mm), TOLERANCE = LINEAR ± 0.5mm, ANGULAR ± 0.5mm (OR AS STATED). ALL SHARP EDGES TO BE REMOVED FROM SHEET METAL PARTS

| | | | | | | | | |
|---|---------------|-------|-------------|------------|--|------------|-------|-------|
| Product | DROP-IN RANGE | | | Product No | The Catering Equipment Company | | | |
| Description | D2RDL | | | | | | | |
| Material/Finish | Thickness | | Desp/Date | | <small>No reproduction or publication of this drawing may be made, and no article may be manufactured or assembled in accordance with this drawing without prior written consent. This prohibition is a term of any contract relating to this drawing. Rights reserved under the Copyright Act 1956 as amended by the Design Copyright Act 1968.</small> | | | |
| Legacy P/N | Weight | 112kg | Quote No. | | | | | |
| Client | | | SO Number | N/A | Dwg No. | DIP-035050 | Issue | |
| Client Project | | | Approved By | | Drawn By | ABB | | |
| | | | | | Date | 15/01/2019 | | |
| E & R MOFFAT LTD, SEABEGS ROAD, BONNYBRIDGE, FK4 2BS, T: +44 (0)1324 812272, E: sales@ermoffat.co.uk, Web: www.ermoffat.co.uk | | | | | Scale | 1:20 | Sheet | 1 / 1 |