

Moffat Specification

Dimensions

Width - 830mm

Depth - 660mm

Height - 462mm

Weight - 38kg

Power Rating

0.580 kw

complete with a 2m long cord set & 13amp plug

Materials

0.7mm 430 Grade St/Steel Gantry Hood

1.2mm 304 Grade St/ Steel Top & Supports

1.2mm 430 Grade St Steel Ancillary Parts

1.2mm Galvanised Steel Inner Supports

4mm Tempered Glass

Neo-Ceram Hot Plates

Quartz Lamps

Installation

Counter Top Flush Fit Cut Out Dimensions

836mm x 666mm x 25mm

Counter Support Cut Out Dimensions

812mm x 642mm

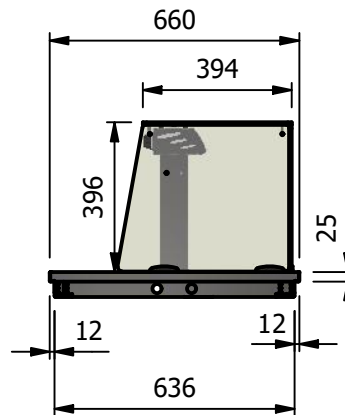
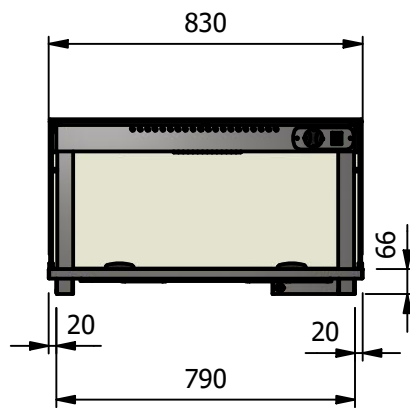

ALL SHEET METAL DIMENSIONS ARE I/S (INSIDE SIZES) (UNLESS OTHERWISE STATED)

ALL DIMENSIONS IN (mm), TOLERANCE = LINEAR ± 0.5mm, ANGULAR ± 0.5mm (OR AS STATED). ALL SHARP EDGES TO BE REMOVED FROM SHEET METAL PARTS

Product	DROP-IN RANGE			Product No								
Description	D2HTSLF											
Material/Finish	Thickness			Desp/Date								
Legacy P/N	Weight	38kg		Quote No.								
Client				SO Number	N/A		Dwg No.	DIP-020191		Issue		
Client Project				Approved By			Drawn By	ABB		-		
							Date	20/12/2018				
E & R MOFFAT LTD, SEABEGS ROAD, BONNYBRIDGE, FK4 2BS, T: +44 (0)1324 812272, E: sales@ermoffat.co.uk, Web: www.ermoffat.co.uk							Scale	1 : 20		Sheet	1 / 2	A4

No reproduction or publication of this drawing may be made, and no article may be manufactured or assembled in accordance with this drawing without prior written consent. This prohibition is a term of any contract relating to this drawing. Rights reserved under the Copyright Act 1956 as amended by the Design Copyright Act 1968.

