

**Important Design Parameters**

On the operators side of the Servery Counter a removable service panel is required to allow access to service heating elements etc. The dimensions of the access aperture must be no less than 669mm x 145mm.

Additionally access is required to manually operate the drain valve. Drain connection is via 15mm lever ball valve.

**Warning**

The unit must be manually filled with water. Capacity 13 litre. A depth of 40mm must be maintained during operation. [water level marker fitted to element cover]

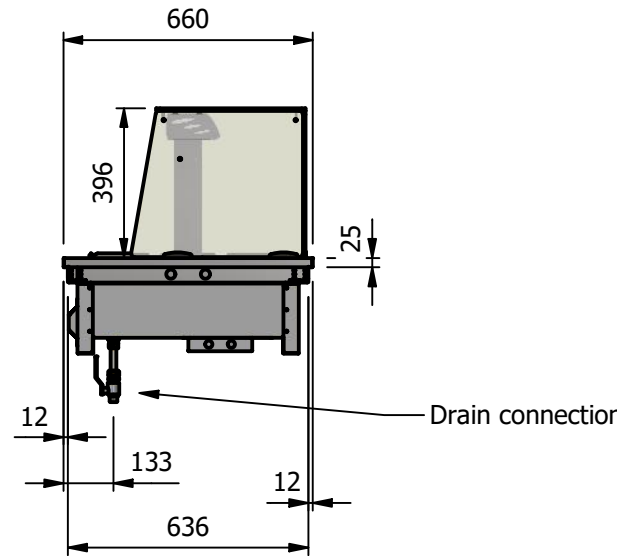
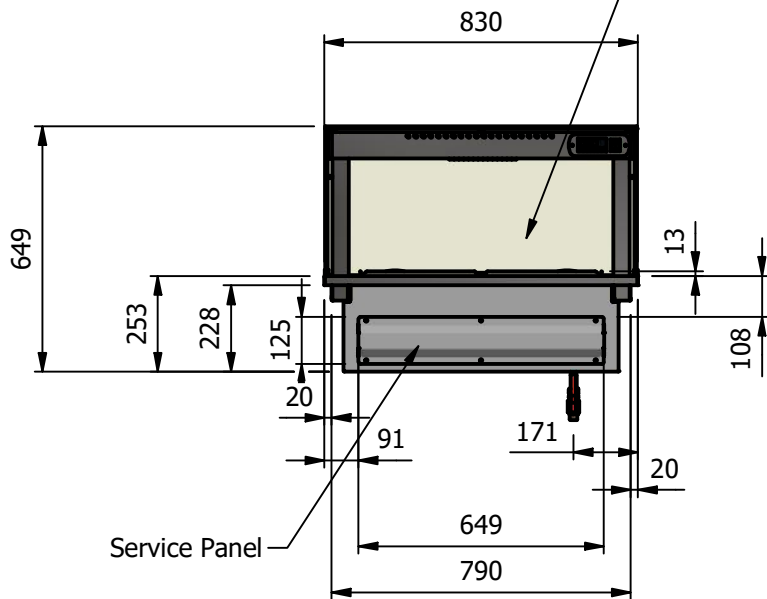

**Moffat Specification**

Wet Heat

Immersion heated Bainmarie Well

Dimensions

Width - 830mm  
Depth - 660mm  
Height - 649mm  
Weight - 48kg

Power Rating

2.22kw  
complete with a 2m long cord set & 13amp plug

Materials

1.2mm 304 Grade St/ Steel Top, Supports & Well  
0.7mm 430 Grade St/ Steel External Structure  
0.7mm Galvanised Steel Undercarrage  
6mm Tempered Glass  
Quartz Lamps

Installation

Counter Top Flush Fit Cut Out Dimensions  
836mm x 666mm x 25mm  
Counter Support Cut Out Dimensions  
812mm x 642mm

ALL SHEET METAL DIMENSIONS ARE I/S (INSIDE SIZES) (UNLESS OTHERWISE STATED)

ALL DIMENSIONS IN (mm), TOLERANCE = LINEAR ± 0.5mm, ANGULAR ± 0.5mm (OR AS STATED). ALL SHARP EDGES TO BE REMOVED FROM SHEET METAL PARTS

Product	DROP-IN RANGE			Product No		<p>The Catering Equipment Company</p>				
Description	D2BMWSLF									
Material/Finish	Thickness			Desp/Date		<small>No reproduction or publication of this drawing may be made, and no article may be manufactured or assembled in accordance with this drawing without prior written consent. This prohibition is a term of any contract relating to this drawing. Rights reserved under the Copyright Act 1956 as amended by the Design Copyright Act 1968.</small>				
Legacy P/N	Weight	48kg		Quote No.			Dwg No.	DIP-022846	Issue	
Client				SO Number	N/A	Drawn By	ABB	-		
Client Project				Approved By		Date	16/01/2019			
E & R MOFFAT LTD, SEABEGS ROAD, BONNYBRIDGE, FK4 2BS, T: +44 (0)1324 812272, E: sales@ermoffat.co.uk, Web: www.ermoffat.co.uk						Scale	1:20	Sheet	1 / 2	<b>A4</b>