

Tray platform 560mm x 360mm

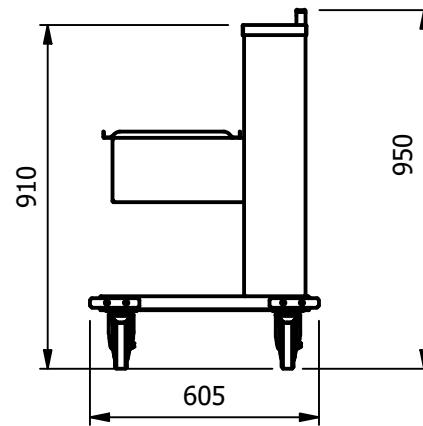
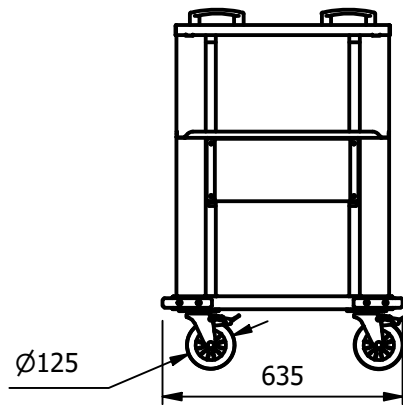
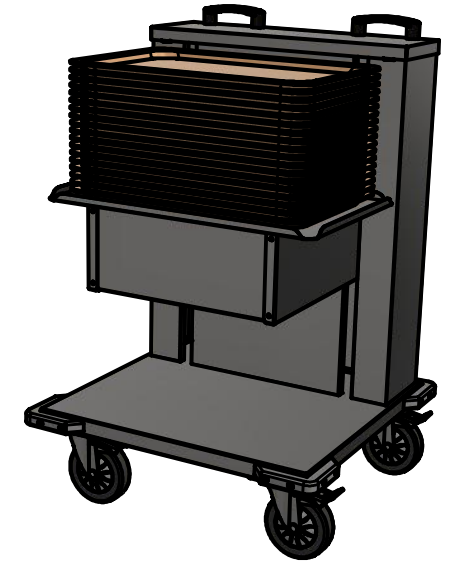

Moffat Specification

Dimensions
 length - 605mm
 Depth - 635mm
 Height - 950mm
 Weight - 50kg

Features
 Tray pickup area 560mm x 360mm

Materials
 2.0mm 304 Grade St/Steel chassis
 1.2mm 430 grade St/Steel body
 Framework 25mm tube St/Steel

Installation
 All swivel castors, two braked

ALL SHEET METAL DIMENSIONS ARE I/S (INSIDE SIZES) (UNLESS OTHERWISE STATED)

ALL DIMENSIONS IN (mm), TOLERANCE = LINEAR ± 0.5mm, ANGULAR ± 0.5mm (OR AS STATED). ALL SHARP EDGES TO BE REMOVED FROM SHEET METAL PARTS

Product	TROLLEYS			Product No						
Description	CTD			<small>© No reproduction or publication of this drawing may be made, and no article may be manufactured or assembled in accordance with this drawing without prior written consent. This prohibition is a term of any contract relating to this drawing. Rights reserved under the Copyright Act 1956 as amended by the Design Copyright Act 1968.</small>						
Material/Finish	Thickness		Desp/Date							
Legacy P/N	Weight	50kg	Quote No.							
Client				SO Number	STD	Dwg No.	079586	Issue		
Client Project				Approved By		Drawn By	N.Raymen	-		
E & R MOFFAT LTD, SEABEGS ROAD, BONNYBRIDGE, FK4 2BS, T: +44 (0)1324 812272, E: sales@ermoffat.co.uk, Web: www.ermoffat.co.uk						Date	15/09/2020			
						Scale	1 : 20	Sheet	1 / 2	A4