

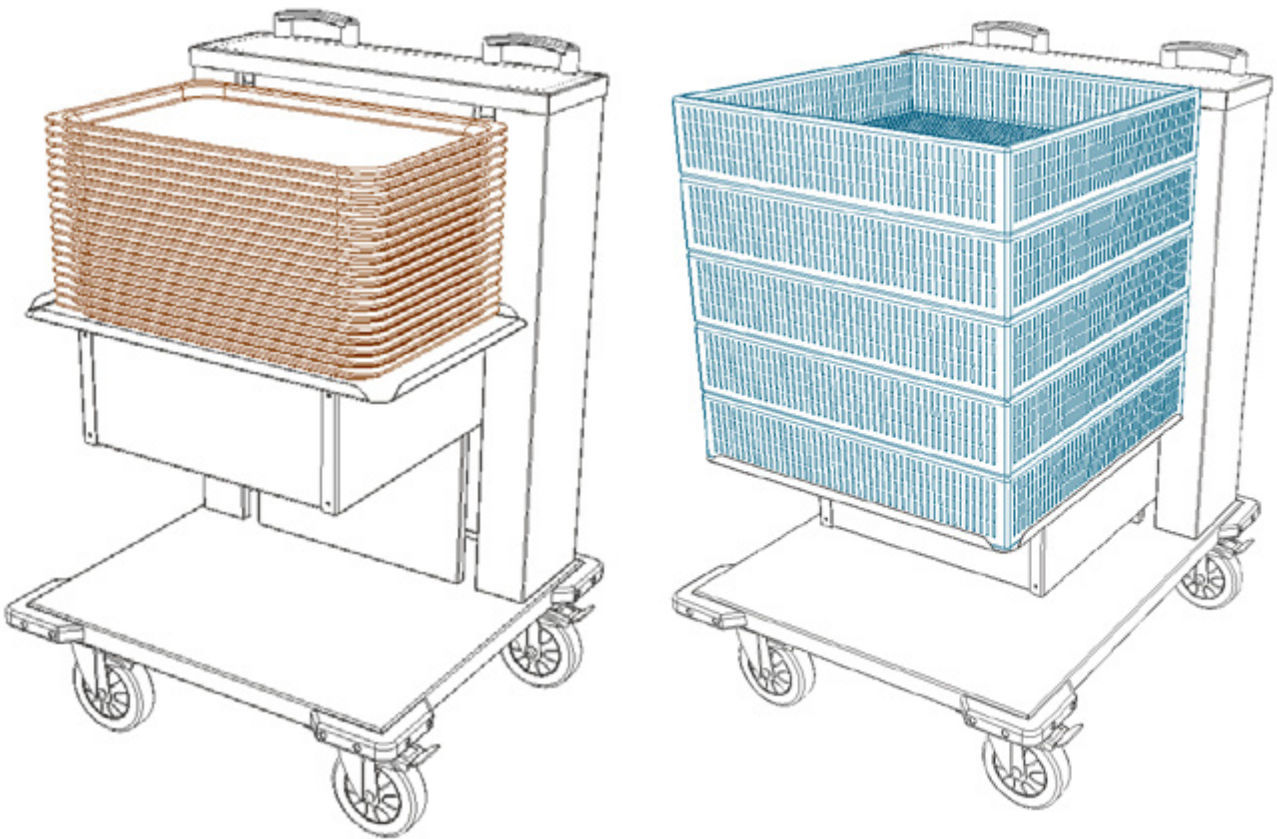

Tray/Basket Dispenser (Cantilever Type)



Operating & Service Manual





To ensure the best results from this unit please take the time to read and follow all safety, installation and maintenance guidelines carefully before proceeding to install. Keep this manual in a safe place for future consultation.



These appliances are CE-marked in compliance with the relevant Low Voltage & EMC Directives. Voltage stated on unit data plate.



Warning! Please pay attention to sections of the manual displaying this symbol.



Warning! Do not attempt to use a hose or water jet to clean this unit. For cleaning instructions, refer to section 15.

The appliance must only be used for the purpose it was designed for and may become unsafe if used for any other purpose. Operators should be trained. The room where this trolley is used must be dry, clean with temperatures between 16°C and 25°C and with a maximum relative humidity of 60%. This unit is for indoor use only and has an IPX4 rating.

Contents

		Page
1	General Installation	3
2	Specification / operation	3
3	Set Up spring tension	4 / 5
4	Cleaning	6

1: General Installation

1. Remove all packaging & plastic coatings from the appliance.
2. Check for any damage.
3. Roll into position and apply the brakes on the operator's side.



Warning: Spring-loaded pop-up tray dispensers system.
Do not insert hands or any object into lifting mechanism, especially when unit is under load.

2: Specification

Model	Weight (kg)	Dimensions L X W X H (mm)
CTD	50	605 x 635 x 950
CBD	60	755 x 635 x 950

Tray and basket dispensers with a spring controlled pop up floating platform.

CTD can hold up to 100 trays

CTB can hold up to six 100mm deep baskets or eight 75mm deep baskets

Operation:

- Set spring tension see page 4 & 5
- Carefully load Trays / Baskets.
- Transport using the push pull handles
- When in position always apply the brakes
- Lift of to tray and stack automatically moves up level

3: Set Up (spring tension)

Setting the Spring Tension

Trays sit on a floating platform. This 'Floating Platform' in turn, is supported by several tension springs. The tension springs are fastened symmetrically behind the lift off removable rear panel.

- First remove any trays or baskets from floating platform.
- Lift off the removable panel, by lifting up & out. (See diagram below)
- Disconnect springs from bottom only, in this way any extra springs will hang loose from the top as spares.
- Springs must be distributed evenly starting at the centre & working outwards.
- After adjustment replace the removable panel. (Locating tabs and slots on base)



Warning: The floating platform springs must be equal on both sides. If not; an imbalance will occur.

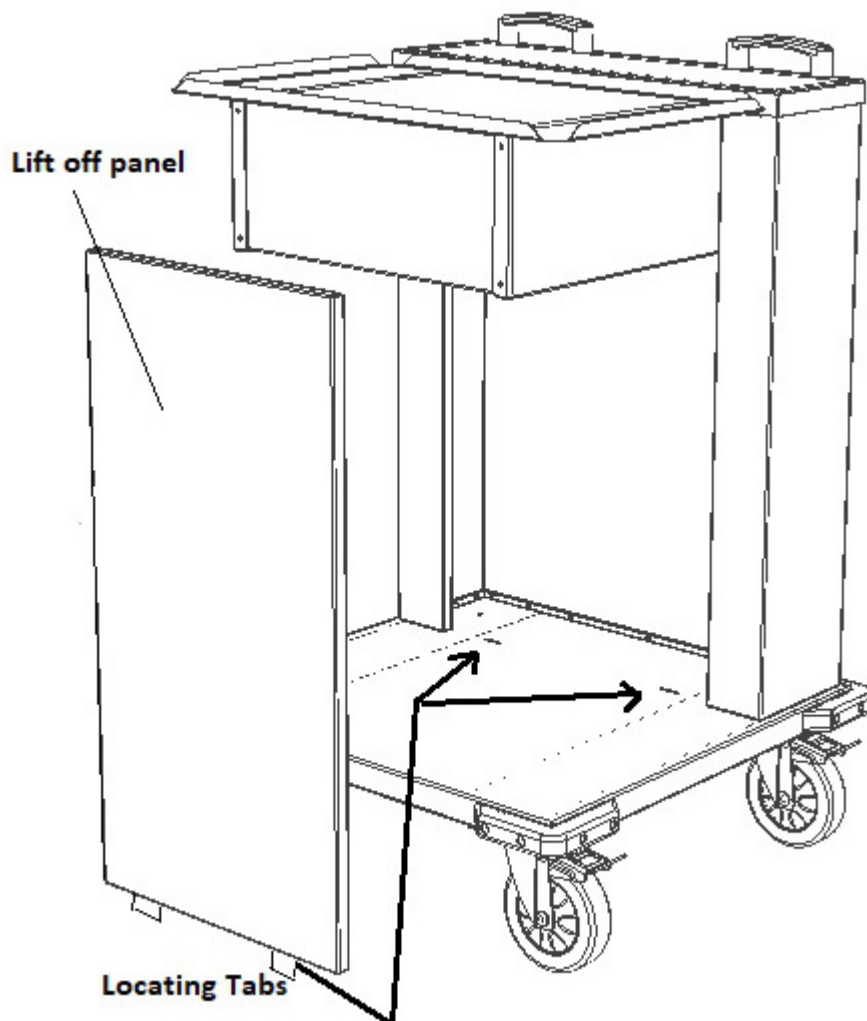

3: Set Up (spring tension)

The 'Floating Platform' is supported by an equal amount of tension springs on each corner. The number of springs equates to the size and weight of trays being used.

Always have two springs connected at each end and add as required moving in towards the centre, add or remove springs accordingly until the top tray is at the required serving level.

The Springs are held in place using a hook & eye arrangement top & bottom. They can be easily attached or detached by just hooking or unhooking the end, into or out of the corresponding hole on the floating support.

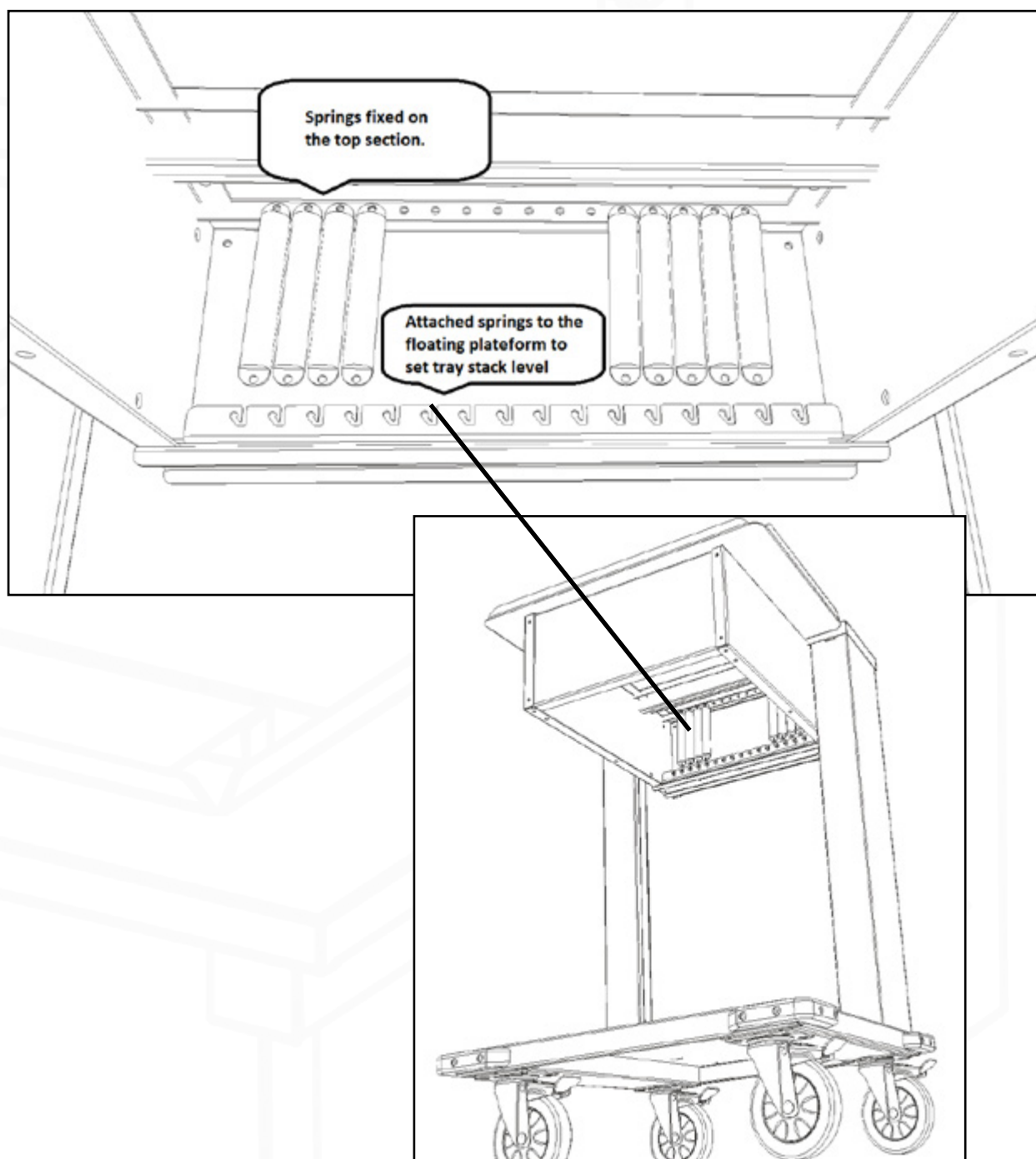

4: Cleaning



Before attempting to clean the unit, please ensure that the Unit is isolated from the electric supply and allowed to cool down, with all food plates and other Dishes removed from the unit.

Do not use a water jet or pressure spray to clean this appliance.

1. Disconnect trolley from mains and wait until appliance has cooled.
2. Wipe clean using hot, soapy water and soft, non-abrasive cloth. Ensure that the stainless steel is wiped in straight strokes following the grain of the material.
3. Wipe dry using a clean cloth. Do not use scouring pads or abrasive cleaners of any type. Shelving and select inner panels can be removed to allow a deeper internal clean. Ensure all panels and fixings are replaced after cleaning operation.
4. Finish by carefully drying with a soft dry cloth or Kitchen Towels.



Do not use scouring pads or abrasive cleaners of any type.

Do not use Solvents, bleach, Caustic Cleaners or biological powders on any surface.



Special care should be taken around electrical parts, avoided excessive use of water.

Take special care when cleaning glass use a soft duster & glass cleaner spray.

Thank you for choosing E&R Moffat!

Scan the QR code below to visit the
E&R Moffat website for further information:

