

## Overview

### Model BBTC (compact)

Specially designed for breakfast, tea & coffee service. An attractive, easy to manoeuvre and very compact trolley service with space for everything required. Perfect for aged care facilities and hospitals.

The mobile ward service trolley allows beverages, refreshments, and light meals to be served to patients and visitors at the bed side or in lounges and other communal areas. Great for use in busy hospitals retirement homes and various other types of healthcare facilities.

Push pull handles at each end and the simple layout facilitates easy positioning and set up. Very easy to use and keep clean, a practical hygienic and versatile design with a wide range of options and features, multiple drawers and runners, for holding baskets pans and ingredient containers etc. Crockery cutlery and condiments carried on board.



## Key Features:

- Provides an attractive & efficient solution for a mobile hot beverage service.
- Easy to keep clean.
- Light and easy to manoeuvre with push pull handles at each end.
- Corner bumper protection.
- Solid stainless steel top set at 900mm from floor level.
- Robust and ergonomic shroud with lockable lid.
- Integral double socket for the water boiler and toast warmer.
- Complete with a 2m long 13amp safety break away cable and plug.
- Mains cable safety breaker.  
(If the trolley is accidentally push away while still plugged into the power socket, the cable will simply pull apart eliminating damage and down time.)
- 10ltr water boiler with drip tray.
- 2 off Ingredient dispensers for coffee and sugar etc.
- Fully extendible top drawer with six lift out plastic containers ideal for tea bags and condiments.
- Lockable top drawers complete with a 4-section cutlery box.
- Lockable second drawer complete with 4 off cereal containers.
- Fold down waste bag holder.
- Discreet pan located in base for cleaning cloth / spray.
- Three dish wash baskets [500mm sq type] on fully extendible runners.
- Castors all swivel and two are fitted with brakes.
- Goose wing grey durable plastic-coated steel outer panels.

## Options:

- **TW1:** 30 slice Toast warmer
- **TW2:** 45 slice Toast warmer
- **BES:** Fold down end shelf:

“Tea and Toast it’s a Tradition”

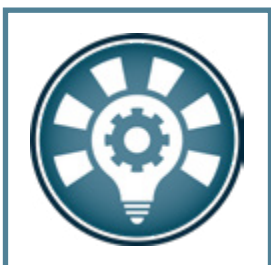



Model	Weight (kg)	L x D x H (mm)	Height to worktop	Power Rating/ Electrical supply	Power Rating with Toast Warmer
BBTC	95	1111 x 620 x 1410	900mm	2.5kw / 13amp	2.8kw / 13amp

**NOTE:**

The stop, start / push, pull force required when fully loaded is 10kg  
 The force required to keep the trolley in motion is 2kg

**BBTC**

Shown with optional toast warmer, model TW1 and optional end shelf BES

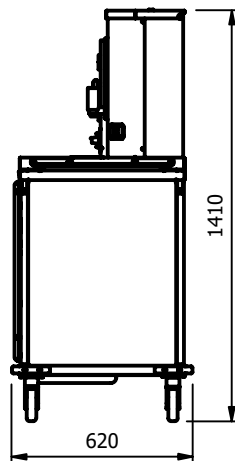
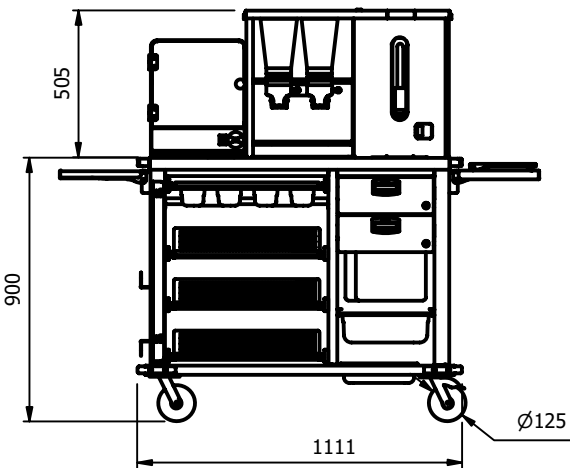
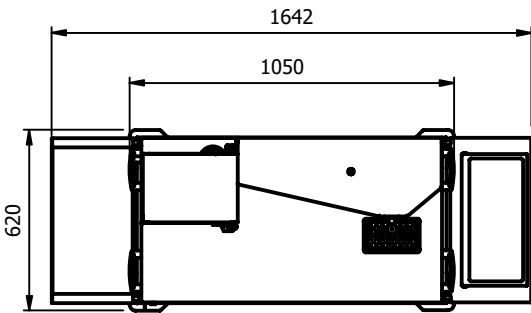

E&R Moffat Ltd.  
 Bonnybridge  
 FK4 2BS  
 Scotland

Find us on:



www.ermoffat.co.uk  
 +44 (0) 1324 812272  
 sales@ermoffat.co.uk