

**Moffat Specification**

Bainmarie well  
 Dry heat  
 Open top with raised lip is designed to hold Gastronorm pans and heats via the residual hot air from the hot cupboard to maintain temperature which gives energy saving efficiency.

Dry Heat  
 Fan Assisted Hotcupboard

Dimensions  
 Length - 1124mm  
 Depth - 665mm (715mm with folded tray rail)  
 Height - 900mm  
 Weight - 63kg

Capacity of Bainmarie  
 Three GN1/1 pans up to 150mm deep  
 [Note:-pans are not supplied, available at extra cost]

Capacity of Hot Cupboard [usable inside space]  
 length - 981mm  
 Depth - 538mm  
 Usable Height Bottom shelf - 204mm  
 Usable Height Top Shelf - 265mm

36 covers & meals [10" plated meals stacked using plate covers]  
 or  
 108 off 10" plates stacked for heating  
 or  
 6 off 1/1GN pans side by side 150mm deep 3 on top 3 on bottom

Power Rating  
 1.9kw with no gantry, 2.34Kw with heated gantry.  
 complete with a 2m long cord set & 13amp plug  
 Removable Fan heating System Sahara Fan Model SF319

Materials  
 1.2mm 304 Grade St/ Steel Top & Supports  
 0.7mm 430 Grade St/ Steel Internal Structure  
 GN 1/1 Grid Shelves with 30mm x 30mm tube supports

Installation  
 All swivel castors, two braked

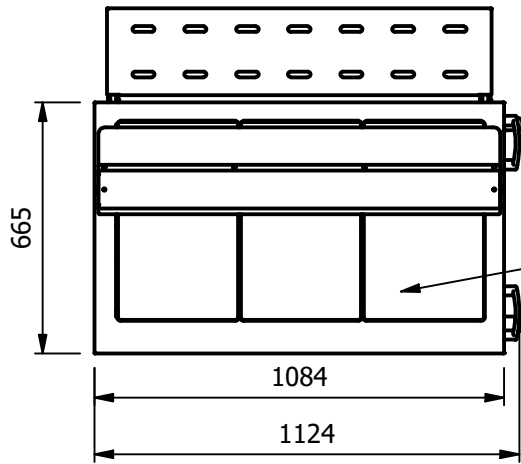
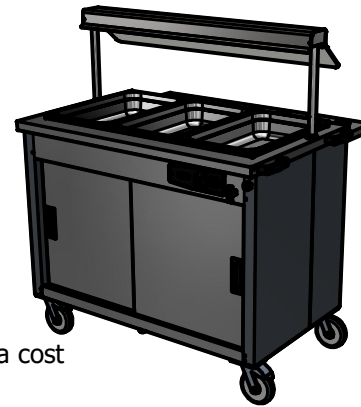

3 x GN 1/1 pan Bain-marie  
 Pans are not included available at extra cost

Push pull handles on operators right hand side

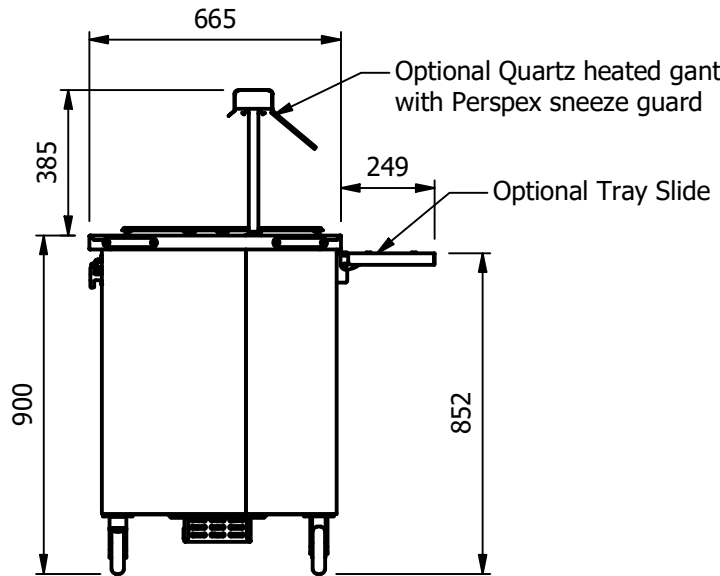

Optional Quartz heated gantry with Perspex sneeze guard

Optional Tray Slide

POWER CABLE ENTRY POINT

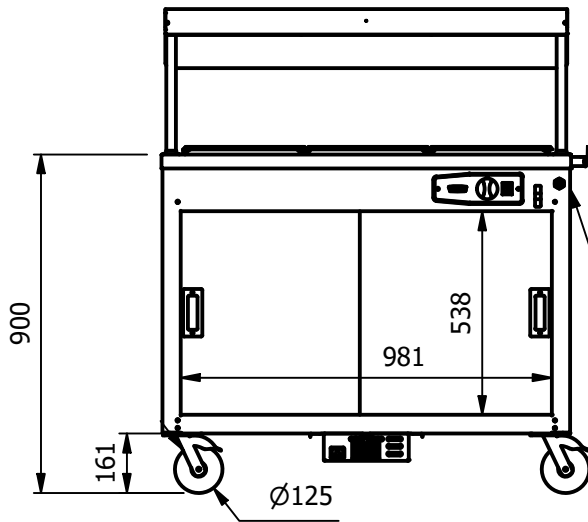

Ø125

ALL SHEET METAL DIMENSIONS ARE I/S (INSIDE SIZES) (UNLESS OTHERWISE STATED)

ALL DIMENSIONS IN (mm), TOLERANCE = LINEAR ± 0.5mm, ANGULAR ± 0.5mm (OR AS STATED). ALL SHARP EDGES TO BE REMOVED FROM SHEET METAL PARTS

Product	FOCUS			Product No							
Description	*** 3FBM ***										
Material/Finish	Thickness			Desp/Date							
Legacy P/N	Weight	63kg		Quote No.	Dwg No.	UMP-083989-1	Issue				
Client				SO Number	STANDARD		Drawn By	N.Raymen			
Client Project				Approved By			Date	19/01/2021			
E & R MOFFAT LTD, SEABEGS ROAD, BONNYBRIDGE, FK4 2BS, T: +44 (0)1324 812272, E: sales@ermoffat.co.uk, Web: www.ermoffat.co.uk							Scale	1 : 20	Sheet	1 / 2	A4

No reproduction or publication of this drawing may be made, and no article may be manufactured or assembled in accordance with this drawing without prior written consent. This prohibition is a term of any contract relating to this drawing. Rights reserved under the Copyright Act 1956 as amended by the Design Copyright Act 1968.

