

Moffat Specification

Bainmarie well
 Dry heat
 Open top with raised lip is designed to hold Gastronorm pans and heats via the residual hot air from the hot cupboard to maintain temperature which gives energy saving efficiency.

Dry Heat
 Fan Assisted Hotcupboard

Dimensions
 Length - 840mm
 Depth - 665mm (715mm with folded tray rail)
 Height - 900mm
 Weight - 54kg

Capacity of Bainmarie
 Two GN1/1 pans up to 150mm deep
 [Note:-pans are not supplied, available at extra cost]

Capacity of Hot Cupboard [usable inside space]
 Length - 697mm
 Depth - 538mm
 Usable Height Bottom shelf - 204mm
 Usable Height Top Shelf - 265mm

24 covers & meals [10" plated meals stacked using plate covers]
 or
 72 off 10" plates stacked for heating
 or
 4 off 1/1GN pans side by side 150mm deep 2 on top 2 on bottom

Power Rating
 1.9kw with no gantry, 2.12Kw with heated gantry.
 complete with a 2m long cord set & 13amp plug
 Removable Fan heating System Sahara Fan Model SF319

Materials
 1.2mm 304 Grade St/ Steel Top & Supports
 0.7mm 430 Grade St/ Steel Internal Structure
 GN 1/1 Grid Shelves with 30mm x 30mm tube supports

Installation
 All swivel castors, two braked

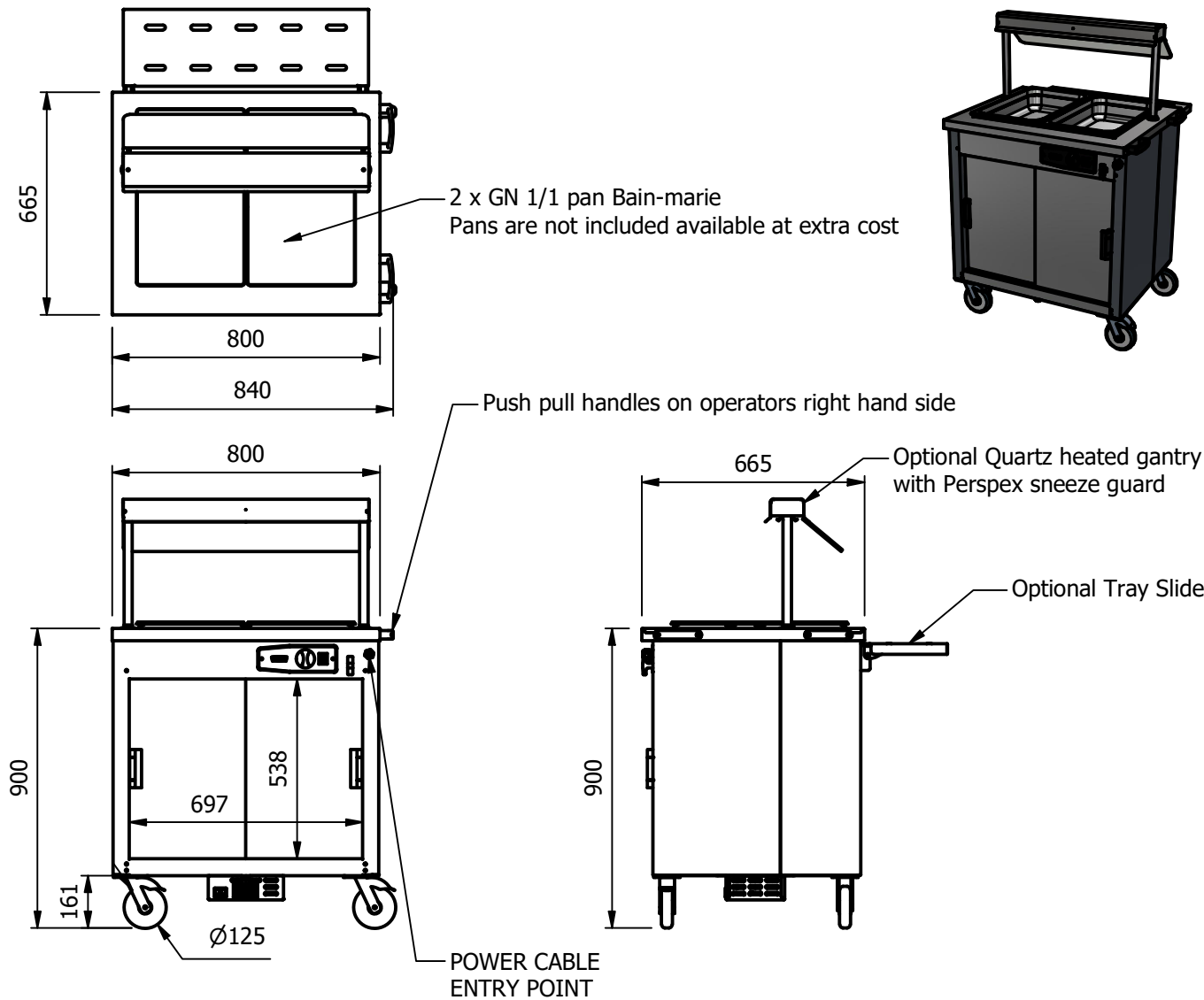
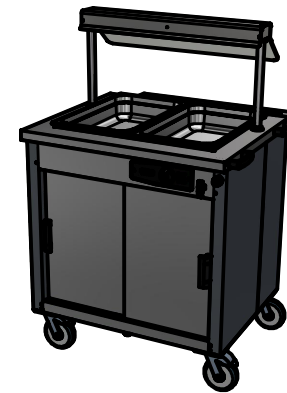

ALL SHEET METAL DIMENSIONS ARE I/S (INSIDE SIZES) (UNLESS OTHERWISE STATED)

ALL DIMENSIONS IN (mm), TOLERANCE = LINEAR ± 0.5mm, ANGULAR ± 0.5mm (OR AS STATED). ALL SHARP EDGES TO BE REMOVED FROM SHEET METAL PARTS

Product	FOCUS			Product No	<p>The Catering Equipment Company</p>	
Description	*** 2FBM ***					
Material/Finish	Thickness		Desp/Date		<p>No reproduction or publication of this drawing may be made, and no article may be manufactured or assembled in accordance with this drawing without prior written consent. This prohibition is a term of any contract relating to this drawing. Rights reserved under the Copyright Act 1956 as amended by the Design Copyright Act 1968.</p>	
Legacy P/N	Weight	54kg	Quote No.	Dwg No.		
Client			SO Number	STANDARD	UMP-085859-1	
Client Project			Approved By		N.Raymen	
E & R MOFFAT LTD, SEABEGS ROAD, BONNYBRIDGE, FK4 2BS, T: +44 (0)1324 812272, E: sales@ermoffat.co.uk, Web: www.ermoffat.co.uk					Issue	
					Date	19/01/2021
					Scale	1 : 20
					Sheet	1 / 2
						A4